

The Lodge of Research,

No. 2429.

Transactions

FOR THE

Year 1911-12.

(Twentieth Year of Publication)

W. BRO. GEO. BONNER (P.M. 523),
P.P.G.Std.B.—W.M.

EDITED BY

JOHN T. THORP, F.R.Hist.S.; F.R.S.L.;
P.A.G.D.C. (Eng.).

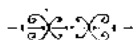

PRINTED BY JOHNSON, WYKES AND CO., MARBLE STREET, LEICESTER

TO THE MEMBERS OF THE "LODGE OF
RESEARCH," No. 2429 LEICESTER.

LEICESTER,

July, 1912.

DEAR BRETHREN,

Owing to the lamented bereavement last year in the family of the W.M. Elect, Bro. the Rev. C. T. MOORE, to whom our sincere sympathy has been extended, I have again the pleasure of greeting you as Worshipful Master of the Lodge.

The volume now before you will, I feel sure, uphold the reputation of our Lodge. Much pleasure has been afforded to those who have had the privilege of attending our meetings, and listening to a most interesting series of Papers.

I take this opportunity of appealing to the members and Correspondence Circle, to secure during the coming year a further accession to our membership, and by so doing increase the usefulness of the work performed, and encourage a love of Masonic Research among the members of the Craft.

Our Lodge Editor, Bro. J. T. THORP, has undertaken the re-publication of the late Bro. HUGHAN'S "Old Charges." I hope the edition will be taken up by the Brethren and that the Lodge funds will not suffer much, if at all, by this memorial to Bro. HUGHAN. Our thanks are due to Bro. THORP for so kindly undertaking the work.

The Lodge will welcome contributions and Papers and be glad to see any of our Brethren from over the seas at our meetings.

In conclusion, I have to thank the Brethren generally for their kindness and courtesy during the two years I have occupied the chair of the Lodge, and I hope, that in the future the Lodge may do as well, if not better, than in the past.

With fraternal regards,

I am,

Yours faithfully,

GEO. BONNER,
W.M.

Officers, 1911-12.

W. Bro. GEO. BONNER (P.M. 523), P.P.G. Std. B., W.M.	
W. Bro. ALFRED LOLE (P.M. 2811),	S.W.
W. Bro. C. F. OLIVER (P.M. 1007), P.P.S.G.W., } Prov. G. Sec., P.A.G. Swd. B. Eng., ... }	J.W.
W. Bro. F. W. BILLSON, LL.B. (P.M. 1391), } P.M., P.P.S.G.W.,	Treasurer.
W. Bro. HENRY J. GRACE (P.M. 2028, W.M. } 3448), P.M., P.P.S.G.W.,	Secretary.
W. Bro. THOS. G. HUNT (P.M. 2865),	S.D.
W. Bro. GEO. W. HUNT (P.M. 2865),	J.D.
W. Bro. W. A. LEA (P.M. 523 and 2865), } P.M., P.P.J.G.W. }	D.C.
W. Bro. J. EASTWOOD PICKARD (P.M. 2081), ...	I.G.
Bro. R. W. MARIES (279),	Tyler.

LODGE EDITOR—W. Bro. JOHN T. THORP (P.M. 2076),
P.M., P.P.S.G.W., P.A.G.D.C. (Eng.).

Address : 57 Regent Road, Leicester.

Treasurer's Address : 23 Halford Street, Leicester.

Secretary's Address : Pen Craig, Enderby, near Leicester.

Objects.

To provide a centre and bond of union for Masonic Students and Brethren of Literary tastes.

To provide and encourage an exemplary rendering of the Masonic Ritual and Ceremonies.

To attract and interest Brethren by means of Papers upon the History, Antiquities and Symbols of the Craft, in order to imbue them with a love for Masonic Research.

And generally—to cultivate Masonic good-fellowship, and promote the Grand Principles upon which the Order is founded.

Dates of Meetings for 1912-13.

September 23rd, 1912.—Installation.

November 25th, 1912.

January 27th, 1913.

March 24th, 1913.

May 19th, 1913.—Election.

Honorary Members.

W. Bro. W. H. BARROW, Mus. Doc.; P.M. 523; P.P.S.G.D.

W. Bro. G. W. BAIN, P.M. 949 Sunderland; P.P.G. Reg. Durham.

W. Bro. F. J. W. CROWE, P.M. 328 Torquay, &c.; P.P.G. Reg. Devon; P.G. Org. (Eng.).

W. Bro. W. B. HEXTALL, P.M. 1085 and 2128; P.P.S.G.W. Derbyshire.

W. Bro. S. S. PARTRIDGE, P.D.P.G.M.; P.A.G.D.C. (Eng.).

W. Bro. the Rev. W. W. COVEY CRUMP, P.P.G. Chap. Cambs.

Members of the Lodge.

Founders.

- *W. Bro. JOHN T. THORP, F.R.Hist.S., P.M. 2076;
P.P.S.G.W.; P.A.G.D.C. (Eng.).
- *W. Bro. W. M. WILLIAMS, P.M. 279; P.P.S.G.W.
- *W. Bro. F. W. BILLSON, LL.B., P.M. 1391; P.P.S.G.W.
- *W. Bro. Rev. H. S. BIGGS, B.A., P.M. 523; P.P.S.G.W.

Joining Members.

- *W. Bro. H. HOWE, P.M. 1391; P.P.S.G.W.; Prov.G.D.C.
- W. Bro. W. H. LEAD, P.M. 2081; P.P.S.G.D.
- *W. Bro. R. B. STARKEY, P.M. 1391; P.P.S.G.W.
- *W. Bro. W. A. LEA, P.M. 523 and 2865; P.P.J.G.W.
- *W. Bro. J. RUSSELL FREARS, P.M. 2081; P.P.S.G.D.
- *W. Bro. H. J. GRACE, P.M. 2028; P.P.S.G.W.
- *W. Bro. G. DAVID POTTS, P.M. 2865; P.P.G. Org.
- W. Bro. S. PERKINS PICK, P.M. 279 and 3078;
P.P.S.G.W.
- W. Bro. GEO. BONNER, P.M. 523; P.P.G. Std. B.
- W. Bro. C. F. OLIVER, P.M. 1007; P.P.S.G.W.; Prov.
G. Sec.; P.A.G.S.B. (Eng.).
- W. Bro. Rev. C. T. MOORE, M.A., P.M. 50 and 779;
P.P.J.G.W.
- W. Bro. ALFRED LOLE, P.M. 2811.
- W. Bro. T. G. HUNT, P.M. 2865; Prov. G.A.D.C.
- W. Bro. GEO. W. HUNT, P.M. 2865, Chap. 3431; Prov.
G. Stwd.
- W. Bro. J. EASTWOOD PICKARD, P.M. 2081.
- W. Bro. F. HOWARD POCHIN, P.M. 2028; P.P.G. Std. B.

* These Brethren have passed the Chair of the Lodge.

Members of the Correspondence Circle.

- W. Bro. E. C. KILBY, P.M. 2081; P.P.G. Stwd.
- W. Bro. GEO. E. TURNER, P.M. 1266 Blandford;
P.P.J.G.W. Dorset.
- Bro. J. CUNNINGHAM, 1391 Leicester.
- W. Bro. Major W. J. FREER, V.D., F.S.A., P.M. 1130
and 1560; P.P.J.G.W.
- W. Bro. A. FERGUSSON, P.M. 1391; P. Prov. S.G.W.
- W. Bro. JOHN CLIFTON, P.M. 279; P.P.G. Swd. B.
- W. Bro. HOWARD J. COLLINS, P.M. 587 and 887
Birmingham; P.P.J.G.D. Warwickshire.
- W. Bro. GEO. W. G. BARNARD, P.M. 943 Norwich;
D.P.G.M. Norfolk; P.A.G.D.C. (Eng.).
- W. Bro. A. BURNETT BROWN, F.S.I., P.M. 1503 Twick-
enham; D.P.G.M. Middlesex; Gd. S. of W. (Eng.).
- W. Bro. C. L. FERNELEY, P.M. 1130; P.P.G. Std. B.
- W. Bro. W. T. COLTMAN, P.M. 523; P.P.G. Std. B.
- W. Bro. E. FORSTER KNIGHT, P.M. 1130; P.P.J.G.D.
- W. Bro. C. A. JAHN, P.M. 2081; P.P.G. Swd. B.
- Bro. C. C. LITTLEFIELD, Sec. "Joseph Webb" Lo.,
Boston, U.S.A.
- W. Bro. P. JOSEPH, P.M. 2387 Manchester.
- W. Bro. FRED W. CROSS, A.M.I.C.E., P.M. 539 Walsall.
- W. Bro. G. J. RODWAY, P.M. 2028 Narborough;
P.P.G. Swd. B.
- Bro. ALBERT H. HAMPSON, S.D. 523 Leicester.
- W. Bro. W. J. C. CRAWLEY, LL.D., D.C.L., F.R.G.S.,
F.G.S., F.R.H.S.; P.M. 357 (I.C.) Dublin; Grand
Treasurer, G.L. of Ireland.
- W. Bro. H. C. BEEBY, P.M. 2081 Leicester; P.P.G. Std. B.
- W. Bro. T. S. H. ASHWELL, P.M. 1391; P.P.G. Std. B.
- W. Bro. THOMAS W. DAVIS, Boston; Rec. Gd. Sec.,
Mass. (U.S.A.).

- W. Bro. J. MACNAUGHT CAMPBELL, C.E., F.Z.S.,
F.R.S.G.S., P.M. 0, 87, 408, 553, 817 Glasgow;
Prov. G. Sec. Glasgow; P.G. Bible Bearer (Scotland).
- W. Bro. S. B. WILKINSON, P.M. 360 Northampton;
P.P.S.G.W. Norths. and Hunts.; P.A.G.D.C. (Eng.).
- Bro. THOMAS C. PERKINS, 491 and 1003; P.P. Gd. Stwd.
Jersey.
- W. Bro. S. RUSSELL BASKETT, P.M. 329 and 1367;
P.P.S.G.W. Dorset.
- W. Bro. GEO. GREEN, P.M. 1330 Market Harborough;
P.P.S.G.W.
- W. Bro. WM. HAMMOND, P.M. 432 and 510 Liskeard;
P.P.S.G.W. Cornwall; P.G.D. (Eng.).
- W. Bro. ROBT. JACKSON, P.M. 413 (S.C.) Glasgow.
- W. Bro. JNO. ROBINSON, P.M. 106 and 128 (I.C.)
Belfast; P.P.S.G.D. Antrim.
- Bro. WM. J. KNIGHT, 2028 Narborough.
- The "MINERVA" LODGE, No. 2433 Birkenhead.
- W. Bro. CHAS. S. BIXBY, P.M. 24 Osawatomie (Kansas),
U.S.A.; D.D.G.M. Kansas.
- W. Bro. THOMAS WALKER, M.D., St. John, N.B.; Past
Grand Master, Gd. Lo. of New Brunswick.
- LEICESTER FREEMASONS' HALL LIBRARY.
- W. Bro. R. J. LULHAM, P.M. 523; P.P.S.G.D.
- W. Bro. S. A. WHITE, Riverside (California), U.S.A.
- Bro. F. J. DALE, 1391 Leicester.
- Bro. C. W. POTTER, 279 Leicester.
- W. Bro. THOS. FRANCIS, P.M. 56 and 804 Havant;
P.P.S.G.D. Sussex; P.P.J.G.W. Hants and I. of W.
- W. Bro. FRED W. LILBURN, P.M. 2028 Narborough;
P.P.A.G.P.
- W. Bro. ROWLAND G. VENABLES, P.M. 611 and 1124
Oswestry, D.P.G.M. Shropshire; P.A.G.D.C.
(Eng.).
- Bro. C. F. CARTER, 1391 Leicester.
- W. Bro. S. M. BANKER, P.M. 186 and 869 London;
P.P.G. Std. B. Herts.

- W. Bro. A. COOPER SMITH, P.M. 50 Hinckley;
P.P.G. Swd. B.
- W. Bro. WALTER TYLER, P.M. 1007 Loughborough;
P.P.G. Swd. B.
- Bro. EDWARD R. FOX, Org. 2081; P.P.G. Org.
- W. Bro. GEO. HELPS, P.M. 50 Hinckley; P.P.A.G.P.
- W. Bro. F. W. MARCHANT, P.M. 50 Hinckley; P.P.A.G.P.
- W. Bro. CHAS. S. BURDON, P.M. 2738 London and 2523
Hounslow; L.R.
- W. Bro. J. H. HALLEY, P.M. 62 Delta (Colorado), U.S.A.
- W. Bro. G. F. LANCASTER, P.M., Prov. A.G. Sec.
Hants. and I.W.; P.G.P. (Eng.).
- W. Bro. W. E. HAWORTH, M.B., C.M., B.Sc., P.M.
2678 Umtali, Brit. S. Africa.
- "MANICA" LODGE, No. 2678 Umtali, Brit. S. Africa.
- W. Bro. T. A. WITHEY, P.M. 1299 and 2608 Leeds;
P.P.G. Reg. West Lanes.
- W. Bro. JOHN THORPE, P.M. 1333 Atherstone.
- W. Bro. J. HUNTER LITTLE, P.M. 1429 Newport, Mon.;
P.P.J.G.W. Monmouth.
- W. Bro. C. W. WATTS, P.M. and Sec. 283 (I.C.) Brisbane;
P.P.G.W. and Pres. B. of G.P. (I.C.) Queensland.
- Bro. W. G. SPENCER, 523 Leicester.
- W. Bro. W. H. RYLANDS, F.S.A., M.R.A.S., P.M. 2076
London; P.A.G.D.C. (Eng.).
- Bro. F. R. KENNING, 192 London.
- W. Bro. CHAS. O. GREEVER, P.M. 110 Des Moines
(Iowa), U.S.A.
- W. Bro. JOHN D. WHISH, P.M. 452 Albany (N.Y.), U.S.A.
- W. Bro. HARRY BLADON, P.M. 2523 and 2675 London;
P.P.J.G.D. Middlesex.
- W. Bro. SEPTIMUS F. POYNOR, P.M. 523 Leicester;
P.P.S.G.D.
- W. Bro. JAMES CLEAVER, P.M. 1330; Prov. J.G.W.
- W. Bro. JAMES M. LAMBERTON, P.M. 21 Harrisburg
(Pa.), U.S.A.

- W. Bro. THOS. M. WOODHEAD, P.M. 2669 Bradford ;
P.P.J.G.W. West Yorks.
- W. Bro. JOHN HASSALL, P.M. 779 Ashby-de-la-Zouch ;
P.P.S.G.W. ; P.A.G.D.C. (Eng.).
- W. Bro. W. H. QUARRELL, M.A., 10 London ; P.M.
779 Ashby-de-la-Zouch ; P.P.G. Reg.
- W. Bro. S. W. FURZE MORRISH, M.I.N.A., P.M. 1593
London ; L.R.
- Bro. WM. THOMAS, 398 Halifax, Nova Scotia.
- W. Bro. S. CLIFTON BINGHAM, P.M. 91 (New Zealand) ;
Gd. Supt. Canterbury (New Zealand).
- MASONIC LIBRARY, Gd. Lo. of Pennsylvania. (Dr.
JULIUS F. SACHSE, Librarian).
- W. Bro. ROBT. PITT, P.M. 433 Brightlingsea ; P.P.G.
Sw. B. Essex.
- W. Bro. F. D. JEAVONS, P.M. 1391 Leicester.
- W. Bro. Lieut.-Col. G. WALTON WALKER, V.D., P.M.
2706, 1838 and 526 Wolverhampton ; D.P.G.M.
Staffordshire ; P.J.G.D. (Eng.).
- W. Bro. THOMAS TAYLOR, P.M. 2149 and 460 Newcastle
(Staffs.) ; P.P.S.G.W. Staffordshire ; P.J.G.D.
(Eng.).
- W. Bro. FRANK HUGHES, P.M. 2706, 482 and 2878
Handsworth ; P.P.S.G.W. Staffordshire.
- Bro. F. H. SHANKS, M.D., 105 Plymouth.
- W. Bro. ARTHUR G. M. GILLOTT, Past Grand Master,
Grand Lodge of Costa Rica.
- W. Bro. W. N. CHEESMAN, J.P. ; F.L.S. ; P.M. 2494
and 566 Selby ; P.P.J.G.W. N. and E. Yorks.
- W. Bro. JNO. E. FAWCETT, J.P., P.M. 974 Bradford ;
P.P.G.W. West Yorks.
- Bro. F. L. GARDNER, 1017 London.
- W. Bro. JOHN BLAKESLEY, P.M. 50 Hinckley ; P.P.S.G.D.
- Bro. W. H. GRIFFITHS, S.D. 1013 Liverpool ; Sec. Liver-
pool Masonic Literary and Philosophical Society.
- W. Bro. Major JOHN BOOTH, V.D., J.P., P.M. 37 Bolton ;
P.P.J.G.W. East Lancs. ; Grand Treas. (Eng.).

- W. Bro. ERNEST MARIETTE, M.B., P.M. 2725 Horra-
Bridge, Devon.
- W. Bro. JAMES H. CODDING, P.M. 108 Towanda (Pa.)
U.S.A.; Gd. Sec. Gen. A.A.S.R. (N.J.) U.S.A.
- W. Bro. Colonel Sir A. H. McMAHON, K.C.I.E., C.S.I.,
P.Z. 228 (S.C.) Quetta.
- Bro. VICTOR J. MOULDER, F.R.H.S., 2694 London.
- W. Bro. W. HERBERT COX, P.M. 2508 Tilbury.
- Bro. THOS. HY. REID, 2028 Narborough.
- W. Bro. W. A. GUNNER, P.M. 1538 London.
- W. Bro. G. A. NOCK, P.M. 1010, Hull.
- W. Bro. W. I. OSBORNE, P.M. 433 Brightlingsea; Prov.
G. Std. B. Essex.
- Bro. S. ERNEST ATKINSON, M.D., J.W. 779 Ashby-de-
la-Zouch.
- W. Bro. SEYMOUR BELL, P.M. 1626 Newcastle-on-Tyne;
D.P.G.M. Northumberland.
- W. Bro. C. LEWIS EDWARDS, F.S.S., P.M. 617 Buenos
Ayres; P.D.A.G. Sec. Argentine Republic.
- W. Bro. ISAAC P. COLLINS, P.M. 342 Coudersport (Pa.),
U.S.A.
- W. Bro. JNO. W. BARKER, P.M. 279, P.M. 3431
Leicester; P.P.S.G.D.
- Bro. WM. MASSEY, 523 Leicester.
- W. Bro. WILLIAM FORRESTER, P.M. 2660, Cranbrook,
Kent.
- W. Bro. THOMAS A. BAYLISS, P.M. 473, 1551 and 2724
Northfield, Worc.; Prov. G. Sec. Worcestershire.
- Bro. A. P. HANFORD, S.W. 279 Leicester.
- W. Bro. H. W. THARP, P.M. 49 London.
- Bro. H. WATSON STILES, 1391 Leicester.
- W. Bro. JOHN LLOYD THOMAS, P.M. 28 New York,
U.S.A.; D.D.G.M. New York.
- W. Bro. HY. KING, P.M. 1329 London.
- Bro. Capt. A. F. G. WARRINGTON, 542 Maulmain, Burma.

- W. Bro. DAVID FLATHER, P.M. 2268 Sheffield.
 Bro. E. S. PHILLIPS, 3 Bridgeport (Conn.), U.S.A.
 W. Bro. CHAS. SWINN, P.M. 2387 Manchester ;
 P.P.J.G.D. East Lancs.
 W. Bro. W. CRAIG, P.M. 508 Singapore, Straits
 Settlements.
 W. Bro. HBT. BEESLEY, P.M. 2268 Sheffield.
 W. Bro. JAMES W. HANBY, P.M. 2078 Scunthorpe.
 W. Bro. Col. J. WALTER STEAD, V.D., P.M. 2608
 Headingly ; P.P. Reg. W. Yorks.
 W. Bro. B. G. HALE, P.M. 2428 Coalville ; P.P.G.S. of W.
 Bro. I. A. COLKIN, 2428 Coalville.
 Bro. J. A. CONNOR, 834 (S.C.) Rangoon.
 W. Bro. Rev. W. K. FIRMINER, M.A., F.R.G.S., P.M.
 229 Calcutta ; P.D.J.G.W. Bengal.
 W. Bro. O. H. BATE, P.M. 1824 (E.C.) East London ;
 P.D.G.W. South Africa (E.D.) ; P.P.G.M. South
 Africa (N.C.).
 W. Bro. W. N. BANCROFT, P.M. 731 Derby.
 W. Bro. THOS. JORDAN, P.M. 1085 Derby ; P.P.J.G.W.
 Derbyshire.
 W. Bro. J. C. BATLIVALA, P.M. and Sec. 614 Rangoon ;
 P.D.G.W. Burma.
 Bro. E. H. PARRY, 482 Handsworth.
 Bro. F. M. HODGSON, 542 Maulmain.
 W. Bro. JOHN BUTTERWORTH, P.M. and Sec. 2387
 Manchester ; P.P.G. Swd. B. East Lancs.
 W. Bro. Rev. J. GEORGE GIBSON, D.D., F.R.S.L.,
 F.R.G.S., P.M. 2279 Oldham ; 431, 3030 and
 3041 ; P.P.G. Chaplain of Northumberland.
 W. Bro. A. H. TYLER, P.M. 1007 Loughborough ;
 P.P.J.G.D.
 W. Bro. JOS. PARSONS, P.M. 523 Leicester.
 Bro. W. TYERS, Stwd. 2081 Leicester.
 W. Bro. R. J. BRAYE, M.R.C.S., P.M. 2081 Leicester ;
 P.P.G. Swd. B.

- W. Bro. G. H. HORNE, D.D.S., P.M. 1242 Douglas;
P.P.S.G.D., Isle of Man.
- Bro. FRANK HAINES, 1391 Leicester.
- W. Bro. W. A. DE WOLF SMITH, P.M. 9 New West-
minster, B.C.; Libn. G.L. of British Columbia.
- W. Bro. WALTER T. ALLAN, P.M. 2929 Stanley;
P.P.S.G.D. Durham.
- W. Bro. J. F. SNAITH, P.M. 1007 Loughborough;
P.P.S.G.W. Leicestershire and Rutland.
- W. Bro. Dr. AUG. NICKEL, P.M. Lodge "Zur Perle am
Berge," Perleberg, Germany.
- "RHODESIA" LODGE, No. 2479 Salisbury, Rhodesia.
- Bro. H. G. BURROWS, A.C.I.S., S.W. 3040 London.
- PROVINCIAL GRAND LODGE LIBRARY, West Yorkshire.
- W. Bro. W. HALL KEYS, P.M. 2878 and 2784 West
Bromwich; P.P.G. Reg. Staffs.
- W. Bro. C. J. LEWIS, P.M. 779 Ashby-de-la-Zouch;
P.P.G. Std. B.
- W. Bro. ARTHUR J. FRANKS, P.M. 502 Rugby; 3222
London.
- Bro. WALTER VARLEY, 1192 Stamford Hill, Natal.
- Bro. WALTER BATES, 523 Leicester.
- Bro. JOHN AGNEW, 320 (S.C.) Saltcoats and Ardrossan.
- Bro. HERBERT BURROWS, 2920 London.
- W. Bro. W. H. DYKE, P.M. "Eureka" Lodge, Buenos
Aires.
- W. Bro. T. E. SHUTTLEWORTH, B.A., F.C.A., P.M.
2268 Sheffield.
- W. Bro. SHERARD JOYCE, M.A., P.M. 779 Ashby-de-la-
Zouch; P.P.G. Std. B.
- W. Bro. LUTHER M. NEILIS, P.M. 17 Topeka (Kan.),
U.S.A.
- Bro. W. H. WOLFERSBERGER, 7 Denver (Colo.), U.S.A.
- W. Bro. F. ROSE TAYLOR, P.M. 2811 Coventry.
- W. Bro. J. R. WILSON, P.M., P.P.S.G.W. Devon;
P.A.G. Std. B. (Eng.).

- W. Bro. CHAS. WILSON, P.M. 1855 Plympton, Devon.
- W. Bro. JNO. T. WHITE, P.M. 395 Leamington.
- W. Bro. T. C. DAWSON, P.M. 1007 Loughborough;
Prov. A.D.C.
- W. Bro. M. S. LOGAN, P.M. 34 Rutland (Vt.), U.S.A.
- W. Bro. W. G. JONES, P.M. 523 Leicester.
- Bro. P. R. FINNIS, 199 Dover.
- Bro. Capt. A. D'CRUZ, 229 Calcutta.
- W. Bro. BENNO LOEWY, P.M. 209 New York, U.S.A.
- W. Bro. F. HORSELL, P.M. 2069 Leeds.
- W. Bro. LEWIS OUGH, F.C.S., P.M. 523 Leicester;
Prov. G. Stwd.
- Bro. HARRY ROBERTS, 279 Leicester.
- W. Bro. T. R. WHITTLEY, P.M. 156 Plymouth.
- W. Bro. G. G. W. WILLCOCKS, P.M. 2910 London; L.R.
- W. Bro. SYDNEY TAYLOR, P.M. 1235 and 1688 Buxton;
P.P.G. Treas. Derbyshire.
- W. Bro. GEO. BARCLAY, P.M. 166 Frankton (N.Z.C.);
P.M. 844 Dunedin; P.D.S.G.W. and P.D.G. Sec.
Otago and Southland, New Zealand; P.G.D.
(Eng.); Senior G.W., G.L. of New Zealand.
- Bro. ARTHUR BOWES, A.M.I.C.E., Sec. 2155 Newton le
Willows.
- Bro. A. A. CARNES, 2695 Harrogate.
- Bro. HERBERT WOODS, 148 Warrington.
- Bro. A. J. GOODE, 1025 Buenos Aires.
- Bro. C. A. BROCKAWAY, 719 Brooklyn (N.Y.), U.S.A.
- W. Bro. W. K. BEDINGFIELD, P.M. 3078 Lutterworth;
Prov. G. Sup. Works.
- W. Bro. R. W. STRICKLAND, P.M. 360 Northampton;
P.P.G. Org. Norths. and Hunts.
- Bro. J. BROCK, 542 Maulmain.
- W. Bro. T. C. COATES, P.M. 57 Lancaster (Ohio), U.S.A.
- W. Bro. JOHN G. REEVES, P.M. 57 Lancaster (Ohio),
U.S.A.

- Bro. E. H. JONES, 2897 Birmingham.
- W. Bro. J. D. JOHNSON, P.M. 1391 Leicester; P.P.G.S. of W.
- W. Bro. WM. TAYLOR, P.M. 2081 Leicester; P.P.G. Swd. B.
- Bro. G. A. H. PAYNE, 2387 Manchester.
- Bro. JOHN BENTLEY, 2387 Manchester.
- Bro. W. N. BRADSHAW, S.D. 2865 Syston.
- Bro. L. S. LAVER, B.A., 2081 Leicester.
- Bro. W. H. MUNRO, 1555 Penang, Straits Settlements.
- Bro. B. H. NICOL, 1268 Rangoon, Burma.
- W. Bro. JOHN HENRY WARD, P.M. 279 Leicester.
- W. Bro. THOMAS JOHN RALLING, P.M. 51 Colchester; Prov. G. Sec. Essex; P.A.G.D.C. (Eng.).
- W. Bro. LOUIS F. ROESE, P.M. 611 Ludlow; P.P.S.G.D. Shropshire.
- W. Bro. ANDREW HUNTER, P.M. 16 Falkirk; Mem. Prov. G. Com. Stirlingshire.
- W. Bro. THOMAS MIDDLETON, P.M. 16 Falkirk; P.G. Jeweller Stirlingshire.
- Bro. ARTHUR NICHOLSON, Treas. 2594 Beeston, Notts.
- W. Bro. JOHN TAYLOR, J.P., F.L.S., F.C.S., P.M. 1402 Torquay; P.P.G.W. Devon.
- W. Bro. THOMAS HARRISON THORPE, F.R.I.B.A., P.M. 802 Derby; P.P.G.S. of W. Derbyshire.
- Bro. C. GIRLING, 2028 Narborough.
- W. Bro. W. W. HARDING, P.M. 2028 Narborough; P.P.G. Purst.
- Bro. C. H. ROBERTS, S.W. 3091 Leicester.
- W. Bro. CECIL POWELL, P.M. 187 Bristol; F.P.S.G.W. Bristol.
- W. Bro. G. MENZIES, P.M. 11 (N.Z.C.) Oamaru, New Zealand.
- The MASONIC LIBRARY, Bristol.
- GENERAL LODGE OF INSTRUCTION, 587 Birmingham.
- Bro. SAMSON SMITH, 523 Leicester.

- Bro. CHAS. BROOK, 279 Leicester.
- W. Bro. G. A. ELLIOTT, P.M. 523 Leicester.
- Bro. JOS. G. WOOD, 1199 Yatton, Somerset.
- W. Bro. J. ELSTON CAWTHORN, P.M. 1221 Leeds ;
P.P.G.D.C. West Yorks.
- W. Bro. W. J. BUNNEY, W.M. 523 Leicester.
- W. Bro. H. B. BROWN, P.M. 581 Manchester.
- W. Bro. J. R. MCFARLANE, P.M. 1555 Penang.
- Bro. L. H. WEMYSS, Sec. 1003 (S.C.) Penang, Straits
Settlements.
- Bro. R. A. KIRKWOOD, 834 Rangoon.
- Bro. J. W. WILLIAMSON, 523 Leicester.
- W. Bro. J. D. STEVENSON, Grd. Sec. of the Gd. Lo. of
Western Australia.
- Bro. H. MILTHORP, J.D. 456 Uttoxeter.
- W. Bro. W. JOHN SONGHERST, F.C.I.S., P.M.; Sec.
2076 London ; P.A.G.D.C. (Eng.).
- Bro. W. FERGUSON SMITH, 2566 Bulawayo.
- W. Bro. LIVERTON T. UNKS, P.M. 57 Lancaster (Ohio),
U.S.A.
- W. Bro. CHARLES S. NORTH, P.M. 57 Lancaster (Ohio),
U.S.A.
- W. Bro. CHARLES C. DITTO, P.M. 57 Lancaster (Ohio),
U.S.A.
- Bro. JOHN H. E. REEVES, 57 Lancaster (Ohio), U.S.A.
- Bro. CHAS. S. PARKER, 3 Spokane (Wash.), U.S.A.
- W. Bro. E. L. HAWKINS, M.A., P.M. 1842, 357 and 478
Oxford ; P.P.G.W. and P.P.G. Sec. Oxfordshire.
- "MOUNTAIN" LODGE, 11(B.C.), Golden, British Columbia.
- W. Bro. J. W. COOK, P.M. 1952 Chapel-en-le-Frith ;
P.P.A.G.P. Derbyshire.
- Bro. A. E. BACHERT, C.E., 327 Robertsdale (Pa.), U.S.A.
- W. Bro. T. M. JOHNSON, P.M. 2609 Chester ; P.P.G. Std. B.
Cheshire.
- W. Bro. THOS. AMBLER, W.M. 1311 Leeds.

- W. Bro. ROBERT S. IVY, District G. Master of Northern China.
- W. Bro. A. C. BROWN, P.M. 1268 Rangoon; P. Dist. J.G.D. Burma.
- W. Bro. THOS. R. JONES, P.M. 1588 Stretford.
Bro. C. H. SLACK, 971 Batley.
- W. Bro. T. FREDK. ISHERWOOD, P.M. 1446 and 3097 London.
- W. Bro. WM. R. BLAIR, P.M. 2706; P.M. 546 and 456 Uttoxeter; P.P.S.G.W. Staffordshire; J.G.D. (Eng.).
- W. Bro. H. DE LANCY COOKE, P.M. 1555 Penang; Dis. G.S. of W., Eastern Archipelago.
Bro. Capt. ROBT. PENTNEY, 1555 Penang.
Bro. SAMPSON FOGG, 1633 Manchester.
Bro. Capt. J. E. LIDDELL, 1555, Penang.
Bro. Capt. A. M. CRICHTON, 1555 Penang.
- W. Bro. CHAS. D. DOBBIE, P.M. 1003 (S.C.) Penang; Treas. 1555 (E.C.) Penang.
Bro. SIDNEY ROBT. BAXTER, 3077 Taplow, Bucks.
- W. Bro. JOSEPH T. WHITEHEAD, P.M. 1441 London; W.M. 2184 Romford; P.P.G. Swd. B. Essex.
- W. Bro. J. A. C. MOWBRAY, P.M. and Sec. 3 Halifax, Nova Scotia.
- W. Bro. FREDK. FOSTER, P.M. 254 Coventry; P.P.G.S. of W. Warwickshire.
Bro. RICHD. L. HOARE, 1268 Rangoon.
Bro. CHAS. H. PARSONS, 1198 Madras.
Bro. WM. ARCHBALD, 1268 Rangoon.
- W. Bro. HUGH BAIRD, P.M. 81 (D.C.) Bulawayo, British S. Africa.
- W. Bro. FRANK JAMES BATES, P.M. 2888 Malmesbury.
W. Bro. TOM C. BATES, P.M. 456 Uttoxeter; P.P. D.G.D.C. Staffordshire.
- The SOUTH WEST LODGE OF INSTRUCTION, Bunbury, W. Australia.

- W. Bro. EDGAR H. ZOLLNER, P.M. 70 (W.A.C.)
Bunbury, W. Australia.
- W. Bro. A. C. MCCALLUM, P.M. 39 (W.A.C.) Perth,
W.A.; Gd. Treasurer of W. Australia.
- W. Bro. HBT. TYLER, P.M. 1007 Loughborough;
P.P.S.G.D. Leicestershire and Rutland.
- Bro. JNO. EDWD. ELLIS, Sec. 3091 Leicester.
- W. Bro. J. JOHNSTONE, F.R.C.S., M.B.; P.M. 2032
Richmond, Surrey.
- Bro. WM. LONNON, R.N., 349 and 966 (S.C.) Malta.
- W. Bro. T. MATTHEWS, P.M. 3152 Fishguard, Pem.
- W. Bro. W. B. SEYMORE, P.M. 117 Charleston (Wash.),
U.S.A.
- Bro. LANCELOT E. WILSON, C.E., 1235 Buxton.
- W. Bro. JAMES A. OVAS, Gd. Sec. Gd. Lodge of
Manitoba.
- Bro. J. W. R. CUTHBERTSON, 834 (S.C.) Rangoon.
DIST. GRAND LODGE OF BURMA.
"RANDLE HOLME" LODGE, 3261 Port Sunlight.
"NORTH YORK" LODGE OF INSTRUCTION, Middles-
brough.
- W. Bro. W. MUTTER, P.M. 614 Rangoon.
- Bro. JAMES J. NOLAN, 183 London.
- Bro. O. T. ELLIOTT, F.R.M.S., 279 Leicester.
- W. Bro. FRANCIS GOODACRE, F.R.G.S., P.M. 1070
Southport; Prov. A.G. Sec. W. Lancs.
- W. Bro. Lieut.-Col. J. A. C. GIBBS, P.M. 1040 Driffield;
P.P.G. Reg. N. and E. Yorks.
- Bro. F. W. HASKARD, J.W. 279 Leicester.
- W. Bro. G. W. W. POPE, P.M. 981 (S.C.) Johannesburg.
- W. Bro. JOHN C. MOOR, F.J.I., P.M. 97, 2039 and 2934 Sun-
derland; Prov. G. Sec. Durham; P.A.G.D.C. (Eng.).
- W. Bro. HENRY HYDE, P.M. 523 Leicester; P.P.J.G.D.
Leic. and Rut.
- W. Bro. JAMES CASTELLO, P.M. 227 London.
- W. Bro. HERBERT SEWELL, P.M. 56 (W.A.C.) Broome,
West Australia.
- Bro. H. C. DERWENT, 3210 Bradford.

- W. Bro. HENRY PECKITT, P.M. 289 Leeds.
 W. Bro. E. W. DONOVAN, P.M. 62 Manchester;
 P.P.G.W. of E. Lancs.
 ALEXANDRA MASONIC CLUB, Leonora, West Australia.
 W. Bro. A. M. BROADLEY, P.D.D.G.M. Malta.
 W. Bro. CHAS. GOUGH, P.M. 2508 and 2661 London.
 W. Bro. CHAS. H. JENKINS, P.M. 689 (E.C.) Auckland,
 New Zealand.
 W. Bro. F. J. BURD, Treas. and Sec. Masonic Board of
 Relief, Vancouver, Canada.
 Bro. O. D. STREET, 209 Guntersville (Ala.), U.S.A.
 W. Bro. J. ERIC COLENZO, Lieut. 7th Gurkha Rifles,
 P.M. 2333 Quetta.
 W. Bro. J. A. SHERREN, F.R. Hist. S., P.M. 170 and 136;
 Prov. G. Sec. Dorset; P.A.G.D.C. (Eng.).
 Bro. F. S. ADAMS, 1648 Bradford.
 Bro. CHAS. HEPPLESTON, 302 Bradford.
 Bro. the Rev. H. H. WHITTAKER, M.A., Chaplain 1561
 Morecambe.
 W. Bro. HY. HARRIS, J.P., P.M. 1349 London.
 W. Bro. GEORGE A. EVANS, W.M. 68 Bristol.
 W. Bro. R. W. BOWERS, J.P., P.M. 15 and 1321 London.
 WARWICKSHIRE MASONIC LIBRARY.
 W. Bro. E. G. DRU-DRURY, M.D., P.M. 828 Grahams-
 town, Cape Colony.
 W. Bro. Rev. GEO. B. GOLDIE, P.M. 2037 Howrah;
 Dist. G. Chap. Bengal.
 Bro. FREDK. H. DOUGHTY, 2081 Leicester.
 Bro. Capt. A. STOREY, 614 Rangoon.
 W. Bro. C. E. STRETTON, P.M. 279 Leicester; P.P.S.G.W.
 Leicestershire and Rutland.
 W. Bro. THOS. INGRAM, P.M.; Prov. G. Stwd. Tyrone
 and Fermanagh.
 THE "PHILLIPS RIVER" LODGE, 81 (W.A.C.) Ravens-
 thorpe, West Australia.
 W. Bro. R. E. WALLACE-JAMES, P.M. 57, etc.; P.P.G. Sec.
 Midlothian; Mem. of Gd. Com., Gd. Lo. of Scotland.
 W. Bro. R. CLAY SUDLOW, P.S.G.D. (Eng.).

- Bro. GEO. E. B. HALES, 3202 and 3237 London.
 Bro. HY. JACKSON, 2081 Leicester.
 W. Bro. C. P. PICKERSGILL, P.M. 827 Dewsbury;
 P.P.G.D. West Yorks.
 Bro. H. A. GREEN, 827 Dewsbury.
 W. Bro. Major W. P. ALEXANDER, P.M. 109, 1960,
 2924, 2998, 3223, 3330 Calcutta, Rangoon, etc.
 W. Bro. Major H. W. ILES, P.M. 1789, 2904, 2924, etc.;
 Dist. G. Sec. Burma.
 Bro. ALMA J. MARSHALL, 279 Leicester.
 HALLAMSHIRE PROVINCE AND COLLEGE, S.R.I.A.
 W. Bro. R. H. BAXTER, P.M. 2320 Castleton; P.P.G.S.
 of W. East Lancs.
 THE "PILGRIM" LODGE, 238 London.
 Bro. Serjt. Major J. W. NESBITT, D.C. 3321 Rangoon;
 P. Dist. G. Stwd. Burma.
 W. Bro. L. G. COTTÈ, P.M. 542 Maulmain.
 Bro. J. A. WADDLETON, 1650 Staindrop, Durham.
 W. Bro. W. G. SARGANT, P.M. 542 Maulmain;
 P. Dist. G. Sd. B. Burma.
 W. Bro. W. T. GOLDSWORTH, P.M. 2224 Long Eaton.
 W. Bro. T. J. WOODCOCK, P.M. 561 Guisborough;
 P.P.G.P. North and East Yorks.
 W. Bro. C. H. BESTOW, P.P.G.P. Essex.
 W. Bro. W. H. DAVIES, P.M. and Sec. 2609 Chester;
 P.P.G. Swd. B. Cheshire.
 W. Bro. NEWTON R. PARVIN, Gd. Sec. Iowa, U.S.A.
 Bro. FRANK OGDEN, 2387 Manchester.
 W. Bro. R. A. DICKSON, P.M. 879 and 2184 Romford;
 P.P.A.G.D.C. Essex.
 W. Bro. J. HEADON BOOCOCK, P.M. 43 Birmingham.
 Bro. C. F. CALLAWAY, 41 Bath.
 W. Bro. HARRY S. HASSALL, P.M. 779 Ashby-de-la-
 Zouch; P.P.G. Pur. Leic. and Rut.
 W. Bro. PERCY H. MELLOR, P.M. 779 Ashby-de-la-Zouch.
 W. Bro. L. L. BALDWIN, P.M. 2428 Coalville; P.P.G.S.
 of W. Leic. and Rut.
 Bro. A. B. MOSS, 2428 Coalville.

- W. Bro. PHILIP BEAUMONT, P.M. 1739 Swadlincote.
 Bro. S. W. MAY, S.W. 1739 Swadlincote.
 W. Bro. H. F. WHYMAN, P.M. 2046 Maidstone and
 3173 Chatham; P.P.G.D. Kent.
 W. Bro. Major-General Sir ROBERT I. SCALLON, C.B.,
 K.C.I.E., D.S.O.; P.M. 2998 Simla, India.
 W. Bro. M. HEANLEY, P.M. 2533 Peterborough;
 P.P.G. Std. B. Norths. and Hunts.
 W. Bro. A. E. SMITH, P.M. 2441 Calcutta; P. Dist.
 G. Swd. B. Bengal.
 THE "KITCHENER" LODGE, 2998 Simla, India.
 W. Bro. GEO. NORMAN, M.R.C.S., P.M. 41 Bath;
 P.P.J.G.W. Somerset.
 W. Bro. J. A. MANYON, P.M. 1268 Rangoon.
 Bro. P. GRANT, 508 and 1152 Singapore, 1165 Hong
 Kong, 2013 Canton, 1912 Foochow, 1268 Rangoon.
 W. Bro. JOHN EVANS, M.D., P.M. 606 Carnarvon.
 Bro. F. P. S. CRESSWELL, F.R.C.S., S.W. 2570 Cardiff.
 Bro. S. R. CHITHAM, 2865 Syston.
 Bro. AR. G. MARSHALL, 2737 London.
 Bro. THOS. EATON, 523 Leicester.
 W. Bro. A. J. TONKIN, P.M. and Treas. 1755 Portishead;
 P.P.S.G.D. Somerset.
 W. Bro. W. K. THOMAS, P.M. 68 Bristol and 1755
 Portishead; P.P.G.S. of W. Bristol and Somerset.
 W. Bro. the Rev. G. H. FREWER, P.M. 373 Huntingdon
 and 2684 St. Ives; P.P.J.G.W. Norths. and Hunts.
 Bro. the Rev. V. C. A. FITZ HUGH, 41 Bath; P.P.G.
 Chap. Herefordshire.
 W. Bro. ALPHEUS A. KEEN, Gd. Sec. New Mexico, U.S.A.
 W. Bro. Dr. W. BEGEMANN, P.P. Gd. Master of
 Mecklenberg.
 W. Bro. M. J. BACON, P.M. 832 Rangoon, 2645 Bassein;
 P. Pres. Bd. G.P. Burma.
 Bro. ERSKINE EDMONDS, I.G. 611 Ludlow.
 W. Bro. H. N. RICH, Gd. Mr. Brit. Columbia.
 W. Bro. J. VROOM, P.D. Gd. Mr. New Brunswick.
 Bro. F. GOODALL, 1268 Rangoon.

- Bro. E. B. C. PRESTON, 1268 Rangoon.
 Bro. W. BENNETT, J.D. 1268 Rangoon.
 Bro. J. G. REID, S.D. 1268 Rangoon.
 Bro. T. OXFORD, 1843 Bareilly, Bengal.
 Bro. B. STEPHENSON, 1268 Rangoon.
 W. Bro. W. G. GRENVILLE SMITH, P.M. 1268 Rangoon;
 P. Dist. S.G.W. Burma.
 W. Bro. CHAS. ABURKOW, Dist. Gd. Mr. Transvaal.
 W. Bro. W. E. WILSON, P.M. 1772 London.
 MANSFIELD (OHIO) MASONIC LIBRARY ASSOCIATION.
 W. Bro. HAROLD COOP, P.M. 166 (N.Z.) New Zealand.
 W. Bro. A. GRAFTON SPRAGUE, P.M. 3320 Llaudriudod Wells.
 Bro. JOHN MCLENNAN, J.W. 318 (S.C.) Dingwall.
 W. Bro. H. PAYNE, P.M. and Sec. + (T.C.) Launceston, Tasmania.
 Bro. Lieut. J. E. G. FESTING, R.E., 3340 London.
 W. Bro. the Hon. F. A. SLACKE, C.S.I., P.M. 3102 Calcutta; P.W.G.R. Bengal.
 W. Bro. Capt. W. F. ELLIS, R.A.M.C., P.M. 2370 Lahore; P.M. 1307 Mooltan and 1308 Dalhousie; Dist. G. Reg. Punjab.
 W. Bro. PERCY T. PEARCE, P.M. 2725 Horrabridge; P.P.S.G.W. Devon.
 W. Bro. F. E. DEMPSTER, C.I.E., P.M. 2839 Calcutta and 2998 Simla; P. Dist. G. Reg. Bengal.
 W. Bro. the Hon. C. P. LUKIS, C.S.I., P.M. 2998 Simla and 3102 Calcutta; P. Dist. G.W. Bengal.
 W. Bro. the Hon. J. S. MESTON, C.S.I., P.M.; P. Dist. S.G.D. Bengal.
 W. Bro. J. WALTER HOBBS, P.M. 2550 London.
 W. Bro. Capt. JOS. GRAY, P.M. 508 Singapore; P. Dist. J.G.W. Eastern Archipelago.
 W. Bro. R. W. WARD, P.M. 476 Carmarthen; Prov. J.G.D. South Wales (W.D.).
 Bro. F. G. KIRKBY, 712 Louth, Lincs.
 W. Bro. A. T. BRAND, M.D., V.D., J.P., P.M. 1040 Driffield; P.P.S.G.W. North and East Yorks.

- Bro. Capt. J. SEYMOUR SUMMERS, 757 and 1100 Bombay.
 W. Bro. WM. H. WHYTE, Gd. Sec. Gd. Lo. of Quebec.
 Bro. CHAS. E. CRANE, 2428 Coalville.
 Bro. WM. ROYLANCE, 884 Wirksworth.
 W. Bro. G. D. KETTLEWELL, M.R.C.S., P.M. 1135
 Ilfracombe.
 Bro. Brig. Gen. R. WAPSHARE, P.W. 2998 Simla.
 W. Bro. J. ROSS ROBERTSON, P.G.W. (Eng.); Past
 Gd. Master of Canada.
 Bro. L. FRENCH BEYTAGH, 757 Bombay.
 Bro. F. W. SNOW, 1198 Madras.
 Bro. Capt. A. MCLENNAN, 609 (S.C.) Glasgow.
 W. Bro. G. RAMSEY SHORT, P.M. 1285 E.C., 229 E.C.
 Calcutta.
 W. Bro. J. W. SAWLE, P.M. 757 Bombay.
 W. Bro. R. I. CLEGG, P.M. 370 Cleveland (Ohio), U.S.A.
 W. Bro. ALEX. BRUCE, P.M. 772 (S.C.) Glasgow; Dep.
 G.M. of Glasgow; Gd. Bard Gd. Lo. of Scotland.
 W. Bro. FREDERICK RUSS GRAYSTONE, P.M. 2924 and
 834 (S.C.) Rangoon; P.J.G.W. of Scottish Free-
 masonry in India.
 W. Bro. ARTHUR W. WISE, P.M. 1270 and 338 (S.C.)
 Bombay; Gd. Sec. of Scottish Freemasonry in
 India.
 W. Bro. H. W. JAMIESON, W.M. 828 (S.C.) Bombay.
 W. Bro. Col. W. J. R. WICKHAM, C.B., P.M. 2333
 Quetta; P. Dist. J.G.W. Punjab.
 W. Bro. Major H. HARVEY JONES, W.M. 2998 Simla.
 Bro. A. CARTER, Sec. 2121 Kasauli.
 Bro. T. CANN HUGHES, F.S.A., 1051 Lancaster.
 Bro. Col. R. H. EWART, D.S.O., 2998 Simla.
 Bro. the Rev. G. D. BARNE, M.A., 2998 Simla.
 Bro. Lt.-Col. R. S. F. HENDERSON, M.B., V.H.S.,
 R.A.M.C., 2998 Simla.
 Bro. Major C. J. PERCIVAL, D.S.O., 2998 Simla.
 Bro. L. W. REYNOLDS, 2998 Simla.
 Bro. Capt. A. C. KENNEDY, R.A., 2998 Simla.
 Bro. Major F. W. BAGSHAW, 2998 Simla.
 Bro. EDWARD H. HART, San Francisco (Cal.).

- W. Bro. W. A. GAYNER, P.M. 906 Bath.
 Bro. WM. J. TRUSTAM, 2343 Bedford.
 Bro. GILBERT T. GORDON, No. 1 Edinburgh.
 W. Bro. NORMAN BUCHANAN, P.M. and Sec. 329
 Yeovil; Prov. S.G.W. Somerset.
 LIBRARY GD. LO. OF SCOTLAND, Edinburgh.
 Bro. WALTER EDWARDS, 1431 Birmingham.
 W. Bro. J. A. S. SCOTT, P.M. 2568 Newcastle-on-Tyne.
 W. Bro. WALTER BROWN, P.M. 3263 Hull.
 W. Bro. WM. HENRY MURCH, P.M. 926 Madras.
 W. Bro. H. GARRETT, P.M. 542 Maulmain; D.G.S.B.
 Burma.
 W. Bro. H. C. WOODMAN, P.M. 3102 Calcutta; Dist.
 J.G.W. Bengal.
 W. Bro. FRANK R. LEECH, P.M. 274 Philadelphia.
 W. Bro. R. C. LEVERSEDGE, P.M. 2048 and 2087;
 P.P.G.D. Middlesex.
 W. Bro. ROBERT BROWN, P.M. 295; Prov. J.G.D.
 Cheshire.
 Bro. Major A. H. D. CREAGH, P.S.W. 415 West Poona;
 413 Meerut.
 Bro. Major H. E. HITCHINS, 2998 Simla.
 W. Bro. WILLIAM KENDALL, 57 Hull; W.M. 1268
 Rangoon; D.G. Std. B. Burma.
 W. Bro. G. F. R. BLACKWELL THURLING, P.M. 542
 Maulmain, Burma.
 W. Bro. C. I. B. MEALIN, P.M. 832 Rangoon; P.D.G.
 Treasurer and P.D.G. Asst. Sec. Burma.
 Bro. FRANK R. GAROOD, 542 Maulmain.
 W. Bro. ALFRED F. ROBBINS, P.M. 1928 and 2712,
 P.G.D. (Eng.).
 W. Bro. GEO. W. CLARK, L.R.C.P.E., 39; P.M. 86 and
 369; P.P.S.G.W. Down (I.C.).
 Bro. C. L. GARRITT, Mount Carmel Lo., Lynn (Mass.),
 U.S.A.
 Bro. Col.-Sergt. F. WELLS, 434 Secunderabad.
 W. Bro. O. W. ALDRICH, P.M. 4 (Ohio), U.S.A.
 Bro. J. W. FARMER, 2428 Coalville.
 Bro. JOSEPH HARRAP, 279 and 3431 Leicester.

- W. Bro. GEO. M. DOE, P.M. 1885 Great Torrington;
P.P.G. Reg. Devonshire.
- Bro. WALTER STELL, 3188 Newcastle-on-Tyne.
- W. Bro. Sergt. JOHN T. S. NOBBS, P.M. 363 (S.C.),
909 (S.C.); 2028 Narborough; P.G. Dir. of
Music; A.S.F.I.
- W. Bro. THOS. CARR, M.D., P.M. 2758 Blackpool.
- Bro. H. L. SNOW, 542 Maulmain.
- W. Bro. T. B. THWAITES, P.M. and J.D. 2576 Mysore.
- W. Bro. J. E. S. TUCKETT, M.A., F.C.S., P.M. 1533
Marlborough; P.P.G. Reg. Wilts.
- Bro. W. W. WARREN, 2865 Leicester.
- W. Bro. CHARLES WYATT FRANCIS, P.M. 1996 and
3391.
- Bro. O. INCHLEY, 1007 and 1492.
- W. Bro. EDWARD STOUT WYCKOFF, M.D., P.M. 19
Philadelphia.
- W. Bro. SILVESTER S. GARWOOD, P.M. 246 Philadelphia.
- Bro. A. E. STEVENSON, 3431 Leicester.
- Bro. WM. STOTT KERSHAW, W.M. St. Chads No. 1129.
- W. Bro. F. C. COOK, W.M. 50 Hinckley and 432.
- Bro. WALTER EVANS, 2865 Leicester.
- Bro. J. E. GENTNER, 2865 Leicester.
- Bro. WM. HELEY HALLSWORTH, W.M., Lo. of Goodwill
465 (E.C.).
- THE MASONIC LIBRARY ASSOCIATION, Cincinnati (Ohio).
U.S.A.
- Bro. CHARLES ARTHUR FLINT, 2599 Engineer Lo.
- Bro. W. E. LAMING, 1268 Rangoon.
- LODGE "FRATERNITY AND PERSEVERANCE," 1746
Benares, India.
- Bro. A. B. CHAPMAN, 2594 Beeston.
- Bro. M. PUGH WILLIAMS, 491 Jersey, 1755 Portishead.
- Bro. A. H. CHAMBERLIN, J.W. 2081 Leicester.
- Bro. F. W. HARRIS, 229 Calcutta.
- DISTRICT GRAND LODGE OF THE TRANSVAAL, Johan-
nesburg.
- GRAND LODGE OF SOUTH AUSTRALIA, Adelaide.

- W. Bro. C. PILLEAN MATTHEWS, 1747 Pretoria;
P.D.J.G.W. Transvaal.
- Bro. A. GATES, 329 Yeovil; P.G.J. Somerset.
- Bro. HENRY SOWDEN, J.D. 489 Bideford.
- Bro. Major G. A. HAWKINS, 438 Cawnpore; 3276
Lucknow; 2904 Maymyo.
- UNITED SERVICE LODGE, No. 24 Thoburn, British
Columbia.
- W. Bro. J. LEVY, P.M.; P.P.J.G.W. Notts.
- Bro. H. N. ORMSBY, 1367 and 2653 Transvaal.
- W. Bro. R. PERKINS, I.P.M. 3433 Shwebo; D.G.A.D.C.
Burma; 2219 Mandalay; 2904 Maymyo; 3464
Chester; 832 Rangoon, Burma.
- W. Bro. D. INNES SMITH, P.M. 2219 Mandalay.
- W. Bro. Compy. Serjt.-Major C. J. GALE, W.M. 2219
Mandalay.
- Bro. R. G. AIYENGAR, 2219 Mandalay.
- Bro. T. PRASAD, 2219 Mandalay.
- Bro. V. V. MAYADU, 2219 Mandalay.
- W. Bro. Lieut. W. C. CLOVER, I.P.M. 2028 Narborough.
- W. Bro. J. G. W. BOULTON, P.M. 2028 Narborough.
- W. Bro. H. SPOONER, P.P.G. Treas. Staffs.
- W. Bro. W. F. BROCKBANK, P.M. 37 Bolton; P.P.G.R.
East Lancs.
- Bro. Capt. M. S. HEWETT, J.W. 563 Umballa.
- W. Bro. C. C. GILL, P.M. 53; W.M. 379; Pro. G. Sec.
Somerset.
- Bro. ARTHUR MARKHAM, 2865; J.D. 1754 Penarth.
- Bro. EDGAR WALLEY, S.D. 3047 Leeds.
- Bro. D. B. HALL, Sec. 3009 Chittagong.
- W. Bro. G. TREVELYAN LEE, W.M. 253 Derby.
- Bro. Rev. J. A. DRYSDALE, S.W. 3330 Rangoon; Chap.
D.G. Lo. Burma.
- W. Bro. W. H. WENDON. P.M. 3020; P.M. 3078;
W.M. 3090; S.W. 869 London.
- Bro. J. T. COOPER, 523 Leicester.
- W. Bro. WM. HY. STAYNES, P.M. 2081 Leicester,
P.P.J.G.W.
- Bro. W. GREENAWAY, 2904 Maymyo.
- Bro. Rev. H. A. HARRIS, J.W. 1660 Eye; Prov. G. Chap.
Suffolk.
-

Legend of Strasburg Cathedral.

There is a quaint old tradition which comes down to us from ancient times, tottering under its load of age and replete with the superstitions of the past.

On the borders of Alsatia there lies a great city, dating its foundation far back to the old Roman days, and rich in those architectural relics of the olden time which are ever so dear to the antiquary.

The story runs that once in every twelve-month, on the eve of St. John, when the quiet burghers of that ancient city are wrapt in peaceful slumber, and when the hour of midnight clangs out from the loud-tongued bell which hangs in the old Cathedral tower, that the spirits of the stonemasons by whose hands the sacred pile was erected, arise from the tomb and once more re-visit the scene of their former labours. Up from the dark and gloomy crypt, along the columned aisles and vast dim nave, across the white-gleaming marble floor, checkered with ghostly shadows that stream from pictured oriels, past the stone-carved statues that keep watch and ward with their swords and sceptres, comes the long train of death-like, night-wandering shadows. Clad in their quaint old mediæval costume, the Masters with their compasses and rules, the Craftsmen with their plumbs and squares and levels, the Apprentice lads with their heavy gavels, all silently greeting their companions, old and dear, with time-honoured salute and token as of yore. While the last note of the deep-mouthed bell is still trembling in the air, reverberating from arch to arch, and dying away amid

the frozen music of the traceried roof, forth from the western portal streams the shadowy throng. Thrice around the sacred edifice winds the waving, floating train, brave old Erwin himself leading the way, while far above, up above the sculptured saints who look down upon the sleeping city, up where at the very summit of the leathery fairy-like spire the image of the Queen of Heaven stands, there floats a cold, white-robed female form, the fair Sabina, old Erwin's well-beloved child, whose fair hands aided him in his work. In her right hand a mallet, in her left a chisel, she flits among the sculptured lace-work of the noble spire, like the Genius of Masonry. With the first faint blush of dawn the vision fades, the phantom shapes dissolve, and the old Masons return to their sepulchres, there to rest until the next St. John's eve shall summon them to earth.

(From "*The Masonic Magazine*," Nov., 1880.)

Correspondence Circle.

The members of the Correspondence Circle shall be placed upon the following footing, that is to say:—

1.—They shall be entitled—

- (a) To have posted to them, as issued, the Summonses convoking the Meetings of the Lodge
 - (b) To be supplied, gratis, with the Annual Transactions of the Lodge.
 - (c) To attend the Meetings of the Lodge.
 - (d) To take part in discussions relating to any papers which may be read, or subject of general Masonic interest which may be introduced.
 - (e) To read papers and introduce discussions on Masonic subjects by arrangement
- (It is hoped that a copy of any paper read will be presented to the Lodge for preservation.)*

They shall not, however, be entitled to vote, hold office, or take part in the management of the Lodge.

The Members of the Lodge will, *as a rule*, be elected from the Correspondence Circle.

- 2.—A Candidate for Membership of the Correspondence Circle shall be subject to election by the Members of the Lodge; (such election shall be by ballot, and two black balls shall exclude.)
- 3.—The names of Candidates must be submitted to the Permanent Committee through the Secretary, at least fourteen days prior to the Meeting at which it is intended they should be proposed.
- 4.—No entrance fee shall be required, and the Annual Subscription shall be 5/-, payable in advance in the month of September.
- 5.—The Lodge reserves to itself the full power of excluding any Member from the Correspondence Circle, whom it may deem unworthy of continued Membership.

NOTE.—All Master Masons, in good standing, whether Members of Lodges in this Province or elsewhere, are eligible for Membership of the Correspondence Circle.

An Antique Apron.*

The frontispiece of the present volume of Transactions represents a very handsome antique French Apron. It is made of white silk, with light blue edging, and the emblems embroidered thereon include pavement, two pillars, square and compasses, sun, moon, stars, five-pointed star, working-tools, emblems of mortality, etc. It is not often that the history of an old apron is so well authenticated as in this instance. It is now in the possession of Dr. Ernest O. Scallon, P.M. 437, P.P.G.Std.B. Somerset, and was worn by his grandfather in the Roman Eagle Lodge, Edinburgh, in which Lodge he was initiated in the year 1797.

This latter Brother was an officer in the Royal Navy and saw much active service abroad; he was at the battle of Camperdown for which he had the medal, and missed the battle of Trafalgar by one day only, owing to his being sent home in the ship which took Nelson's last despatches the day before the battle. It is most probable that he obtained the apron from a French Mason when abroad, and was courteously allowed to wear it in the Scotch Lodge, regulations in respect to Masonic regalia being then much less rigid than at the present time.

* *Vide* Plate I., Frontispiece.

The Roman Eagle Lodge, No. 160 (formerly 212), referred to above, has been a very distinguished Lodge, and many notable men have from time to time belonged to it. It was chartered by the Grand Lodge of Scotland on February 7th, 1785, to meet in Edinburgh, and still meets there regularly twice a month.

One of the founders of the Lodge was Dr. John Brown, an eminent Edinburgh practitioner; he was, during his membership, the moving spirit of the Lodge, a peculiarity of the meetings being that Latin alone was allowed to be spoken, and the minutes also written in that language. He was remarkable for the readiness with which he could translate Masonic technicalities and phrasology into Latin, which language he spoke at all times with the same fluency as his vernacular Scotch.

In its early days the Roman Eagle Lodge was characterised by its extravagant convivialities, and Dr. Brown himself was perhaps one of the deepest of its drinkers. He had at one time a very lucrative practice and was highly respected; latterly, however, owing to his drinking habits, he became very impecunious and was several times imprisoned for debt. There is at least one reference to this in the Minute-Book of the Lodge, where it states that on one occasion his health was drunk by the Brethren, and after stating that he was not present on account of imprisonment, the minute proceeds:—"They" (the Brethren) "went and heard him in Jail."

The following specimen of a Lodge Minute, as written by Dr. Brown, has been communicated by Bro. R. E. Wallace-James, of Edinburgh, a member of the Correspondence Circle of this Lodge; it is a most interesting extract and worthy of being placed on record.

"Edinburgi iv. Kalen. Septem. 1785.

Quibus rebus peractis, causa Fratrum recens receptorum, item ob perfectionem artis cognitionem, Magister suum Pro Magistrum in sedili collocatum, Circulo Profecit. Is elegantissima habita prælectione non solum imperitiores; verum etiam totius gentis atque ipsius Aquilæ Circuli, peritissimos, summa artis Scientia instruxit. Hoc officio peracto solenniter circulus clausus est.

Joannes Bruno Mag. pro Magistro
præterito agens
Sam Lynch, pro Magist ut Magister."

Proper names when rendered into Latin in the Minutes are at times rather bewildering, for instance, "Donaldides" at first blush is not easily recognised as "McDonald"; "Vallesius" for Bro. Walls, "Querci Caput" for Bro. Aitkenhead, "Ruficeps" for Bro. Redhead and "Hieme" for Bro. Winter are also curious.

The neighbouring Lodges in Edinburgh are also amusing—"Circuli Aedificatorum" for Lodge Journeymen, "Divi Andreae" for St. Andrew's, "Cohortis Edinensis Propugnatrix" for Edinburgh Defensive Band, "Tormentorum viæ" for Canongate and "Canonicæ Viæ Kilvinensis" for Canongate Kilwinning, may be taken as examples.

After Dr. Brown's death in 1788 the use of Latin in the Lodge very soon ceased and was never revived.

J. T. T.

The Ninety-Ninth Meeting

of the Lodge was held on Monday, September 7th, 1911, at the Masonic Hall, Syston. The Worshipful Master, Bro. GEO. BONNER, presided. Seven other members of the Lodge and two Visitors were present.

The WORSHIPFUL MASTER explained the business of the Special Meeting and invited comment.

In accordance with notice of motion, signed by seven members of the Lodge, given at the last regular meeting held May 22nd, 1911, it was proposed by Bro. H. J. GRACE, seconded by Bro. W. A. LEA, and carried unanimously, that the Lodge be held in future at the New Masonic Hall, London Road, Leicester.

Apologies for non-attendance were received from Bro. Rev. C. T. MOORE, S.W., and Bro. R. B. STARKEY, P.M. The Lodge was closed in due form.

The One Hundredth Meeting

and

Nineteenth Anniversary

of the Lodge was held by Dispensation at Freemasons' Hall, London Road, Leicester, on Monday, September 25th, 1911. The Worshipful Master, Bro. GEORGE BONNER, P.P.G.Std.B., presided, and was supported by a large number of Brethren, among whom were the following, viz. :—

Members.—Bros. T. G. HUNT, as S.W.; A. LOLE, as J.W.; F. W. BILLSON, P.M., Treasurer; H. J. GRACE, P.M., Secretary; G. W. HUNT, I.G.; R. W. MARIES, Tyler; J. T. THORP, P.M., Lodge Editor; S. PERKINS PICK.

Members of the Cor. Cir.—Bros. Rev. W. W. COVEY CRUMP, P.P.G. Chap. (Cambs.), etc.; F. R. GRAYSTONE, P.M. 2924 and 834; W. G. JONES, W.M. 523; M. HEANLEY, P.M. 2533; F. W. LILBURN, P.M. 2028; F. H. POCHIN, P.M. 2028; R. H. WARREN, P.M. 1391; F. J. DALE, 1391; C. C. CRANE, 2428; F. H. DOUGHTY, 2081; J. E. GENTNER, 2865; J. PARSONS, P.M. 523; G. J. RODWAY, P.M. 2028; F. W. HASKARD, 279; F. G. KIRKBY, 712; C. GIRLING, 2028; J. E. ELLIS, 3091; H. WATSON STILES, 1391; A. P. HANFORD, J.W. 279; J. W. WILLIAMSON, 523; E. R. FOX, 2081.

Visitors.—Bros. E. HOLMES, D.P.G.M.; JOS. YOUNG, P.M. 523, P.P.S.G.W.; W. T. TOPOTT, P.M. 279; G. W. BAILEY, 2865; E. T. SHARDLOW, 2081; C. WATTS, 2028; GEO. SIME, 424.

The SECRETARY read the Dispensation from the PROVINCIAL GRAND MASTER authorising the Meeting to be held at Leicester.

The Minutes of the last Meeting were confirmed, and the following nine Brethren and three Lodges were elected to the Correspondence Circle of the Lodge, viz. :—

- 726. Bro. WALTER EDWARD LAMING, 1268 Rangoon.
- 727. LODGE "FRATERNITY AND PERSEVERANCE,"
1746 Benares, India.
- 728. Bro. A. B. CHAPMAN, 2594 Beeston.
- 729. Bro. M. PUGH-WILLIAMS, 491 Jersey; 1755
Portishead.
- 730. Bro. A. H. CHAMBERLIN, S.D. 2081 Leicester.
- 731. Bro. F. W. HARRIS, 229 Calcutta.
- 732. DISTRICT GRAND LODGE OF THE TRANSVAAL,
Johannesburg, S. Africa.
- 733. GRAND LODGE OF SOUTH AUSTRALIA, Adelaide.
- 734. Bro. C. P. MATTHEWS, 1747 Pretoria, P. Dist.
J.G.W. Transvaal.
- 735. Bro. A. GATES, 329 Yeovil.
- 736. Bro. H. SOWDEN, J.D. 489.
- 737. Bro. Major G. A. HAWKINS, 438 Cawnpore; 3276
Lucknow; 2904 Maymyo.

Owing to the regretted absence, through family bereavement, of the W.M. Elect, Bro. Rev. C. T. MOORE, the WORSHIPFUL MASTER on his behalf invested the following Brethren as the officers for the ensuing year, viz.:—

Bro. A. LOLE,	S.W.
„ F. W. BILLSON,	Treasurer.
„ H. J. GRACE,	Secretary.
„ T. G. HUNT,	S.D.
„ G. W. HUNT,	J.D.
„ R. W. MARIES,	Tyler.

On the proposition of Bro. GRACE, seconded by the WORSHIPFUL MASTER, supported by Bro. LOLE and the D.P.G.M. Bro. E. HOLMES, Bro. J. T. THORP was unanimously requested to continue his services as Lodge Editor, with the best thanks of the Brethren for his past aid and valuable contributions. Bro. THORP duly acknowledged the vote and consented to act for another year.

The Treasurer, Bro. F. W. BILLSON, P.M., on presenting the following report, received a hearty Vote of Thanks for his services.

LODGE OF RESEARCH, No. 2429, LEICESTER.

Balance Sheet, 1910=11.

GENERAL ACCOUNT.			
	RECEIPTS.		PAYMENTS.
1910.		£ s. d.	1910-11.
September 14.—Balance in hand	50 15 4	Grand Lodge Dues ...
Subscriptions received:—			Provincial Grand Lodge Dues ...
Members ...	22	1 0	Rent of Hall ...
Correspondence Circle ...	107	0 6	Tyler's Fees ...
	129	1 6	Printing, &c. :—
Joining Fees	6 6 0	Gibbons & Co. ...
Sale of Transactions	9 16 8	Bro. Lead... ..
Bank Interest	2 16 0	Seale & Riley ...
			Johnson, Wykes & Co. ...
			112 2 2
			Postages :—
			Secretary ...
			Treasurer ...
			Editor of Transactions ...
			10 11 1
			0 16 6
			2 0 8
			13 8 3
			Balance ...
			55 17 1
			£198 15 6
			£198 15 6
PUBLICATION ACCOUNT.			
1910.		£ s. d.	
September 14.—Balance in hand	55 5 9	Printing :—Johnson, Wykes & Co. ...
Receipts, 1910-11	40 0 4	Postages ...
			Balance ...
			11 14 3
			3 5 5
			80 6 5
			£95 6 1
			£95 6 1

36

Audited and found correct, 19th September, 1911.

F. W. BILLSON, P.M.,
Treasurer.

ALFRED MOLE, S.D.
W. A. LEA, P.M., D.C.

Bro. THORP, in referring to the publication account, suggested a reprint of a volume of the late Bro. Hughan's works as a memorial to him.

Bro. W. A. LEA, P.M., was elected to represent the Lodge on the Committee of General Purposes.

The SECRETARY read the following Paper by Bro. Clement E. Stretton, P.M. 279; P.P.S.G.W.

Operative Free Masonry.

By W. Bro. CLEMENT E. STRETTON, P.M. 279;
P.P.S.G.W.

The Transactions of the Lodge of Research for the year 1909-10, page 79, give the report of a Paper, which contained the reason "Why the writer became a member of the Worshipful Society of Free Masons, Rough Masons, Wallers, Slaters, Paviers, Plaisterers and Bricklayers.

Since the publication of that Paper, the Operative Society has decided that it is perfectly in order for more details of their Craft to be made known.

Operative Free Masons, from the very earliest period of their existence, have always divided their work—and consequently the Masons—into two distinct classes, namely: SQUARE MASONS and ARCH MASONS, the reason being, that the art of performing straight and square work required less skill, and was worth less

wages, than the art of making arches, bridges and all kinds of curved, carved or graved work.

Each of the two branches of the trade was divided into seven degrees, viz.:—

- (1.) Apprentice to the Craft of Free Mason.
- (2.) Fellow of the Craft of Free Mason.
- (3.) Super Fellow of the Craft of Free Mason.
- (4.) Super Fellow Erector of the Craft of Free Mason.
- (5.) Super-Intendent of the Craft of Free Mason.
- (6.) Passed Master of the Craft of Free Mason.
- (7.) Master Mason of the Craft of Free Mason.

The reason why the Craft was divided into the seven degrees, was that when King Solomon commenced to build his Temple upon Mount Moriah, he made the site Holy Ground, and commanded that

“the house shall be built of stone made ready before it was brought thither: so that there shall be neither hammer nor axe nor any tool of iron heard in the house, while it was in building.”

To comply with this command it was necessary for every stone to be made to perfect size and gauge in the second stone-yard; then for it to be fitted and marked by Mark Masons in the third degree stone-yard, in order that the Erectors in the fourth degree on the actual site of the structure, could place each stone in its proper position, without the use of any tool of iron.

The ancient Operative system of marking is still known and preserved, and from an examination of the marks, an Erector can at once decide if a stone belongs to the East, South, West or North wall of the building.

The "course mark" gives the number of the course of stones to which it belongs, and the "bed or basis" mark gives the proper basis upon which the stone is to be fixed.

The Super-Intendent of the Works issues the required "marked diagrams" showing every stone with its own marks, and also the numbers of the stones to adjoin it in each direction. It will thus be seen, that if the "marking" was properly performed, the command of the king could be carried out without difficulty. However, the Operative information proves, that on one occasion a key-stone and a North-East corner head-stone were wrongly marked, with the result that some delay was caused at the time when the Temple was nearly completed.

APPLICATION FORMS.

In the Operative system of working, every person who desires to be made an Apprentice, or to be promoted to a higher degree in the Craft, *must* fill up the necessary application form.

There are seven forms for the seven degrees, and they are known by the letters A to G.

The forms relating to the first five degrees have to be presented to The Super-Intendent of the Works, but those relating to the sixth and seventh degrees must be addressed to The Masters.

Forms A and B have been published in the 1909-10 Transactions of this Lodge—pp. 81-83—the other forms, C, D, E, F, G, being as follows:—

Form C.

Application to the Super-Intendent of the Works of
 THE WORSHIPFUL SOCIETY OF FREE MASONS,
 ROUGH MASONS, WALLERS, SLATERS, PAVIORS,
 ——— PLAISTERERS AND BRICKLAYERS. ———

I, _____, having well and truly served
 as a Fellow of the Craft of Free Mason for one year,
 and being of the age of twenty two years, humbly crave
 to be advanced to the honourable degree of Super
 Fellow of The Craft of Free Mason—————I further
 promise and swear that if once advanced to the Third
 degree of the Fellowship I will for ever conform to all
 the ancient charges, usages and established customs of
 the Fraternity, as Super Fellows have done in all ages.

Witness my hand this _____ day of _____ 191

Signed.....

Witness.....

Certificate of Character.

Signed.....

Super-Intendent of the Works.

Enrolled..... Approved.....

Grand Master Mason VII°.

Signed.....

Registrar.

Form D.

Application to the Super-Intendent of the Works of
 THE WORSHIPFUL SOCIETY OF FREE MASONS,
 ROUGH MASONS, WALLERS, SLATERS, PAVIORS,
 ——— PLAISTERERS AND BRICKLAYERS. ———

I————having well and truly served as a Super Fellow
 of the Craft of Free Mason for one year, and being of
 the age of twenty-three years, humbly crave to be further
 advanced to the honourable degree of Super Fellow
 Erector of the Craft of Free Mason.

I further promise and swear that if once advanced to
 the Fourth degree of the Fellowship I will for ever
 conform to all the ancient charges, usages and established
 customs of the Fraternity, as Super Fellow Erectors
 have done in all ages.

Witness my hand this day of 191

Signed.....

Witness.....

Certificate of Character.

Signed.....

Super-Intendent of the Works.

Approved.

Signed.....

Grand Master Mason VII^o.

Enrolled.

Signed.....

Registrar.

Form E.

Application to the Super-Intendent of The Works of
THE WORSHIPFUL SOCIETY OF FREE MASONS,
ROUGH MASONS, WALLERS, SLATERS, PAVIORS,
PLAISTERERS AND BRICKLAYERS.

I, _____, having well and truly served
as a Super Fellow Erector of the Craft of Free Mason
for one year, and being of the age of twenty four years,
humbly crave to be raised to the honourable degree
of Intendent of the Craft of Free Mason.

I further promise and swear that if once raised
to the Fifth degree of the Fellowship I will for ever
conform to all the ancient charges, usages and established
customs of the Fraternity, as Menatzchim have done in
all ages.

Witness my hand this _____ day of _____ 191

Signed.....

Witness.....

Certificate of Character.

Signed.....

Super-Intendent of the Works.

Approved.

Enrolled.

Signed.....

Signed.....

Grand Master Mason VII^o.

Registrar.

Form F.

Application to The Masters of THE WORSHIPFUL
 SOCIETY OF FREE-MASONS, ROUGH MASONS,
 WALLERS, SLATERS, PAVIORS, PLAISTERERS AND
 ————— BRICKLAYERS —————

I, _____, having well and truly served
 as Intendent and Super-Intendent of the Craft of Free
 Mason for one year, and being of the age of twenty five
 years, humbly crave to be Exalted to the honourable
 degree of Passed Master of the Craft of Free Mason.—

I further promise and swear that if once exalted
 to the Sixth degree of the Fellowship I will for ever
 conform to all the ancient charges, usages, and estab-
 lished customs of the Fraternity, as Harodim have done
 in all ages.

Witness my hand this _____ day of _____ 191

Signed...

Witness...

Certificate of Character...

Signed...

Super-Intendent of the Works.

Approved...

Signed...

Enrolled...

Grand Master Mason VII°.

Signed...

Registrar.

Form G.

Application to The Masters of THE WORSHIPFUL
SOCIETY OF FREE MASONS, ROUGH MASONS,
WALLERS, SLATERS, PAVIORS, PLAISTERERS AND
BRICKLAYERS.

I, _____ having well and truly served
as Passed Master, and Deputy Master Mason for five
years, and being of the age of thirty five years, humbly
crave to be enthroned in the honourable and exalted
degree of Master Mason of the Craft of Free Mason.

I further promise and swear that if once enthroned
in the Seventh degree of the Fellowship I will for ever
conform to all the ancient charges, usages and estab-
lished customs of the Fraternity, as Enthroned Master
Masons have done in all ages.

Witness my hand this _____ day of _____ 191

Witness...

Signed...

Certificate of Character and Skill.

Signed

Third Master Mason VII°.

Approved...

Signed...

Enrolled...

Grand Master Mason VII°.

Signed...

Registrar.

About a year ago Bro. J. P. Simpson, P.A.G. Registrar, wrote a Paper, which was afterwards printed and circulated by the Grand Lodge of England, in which he stated "The ritual of Freemasonry, as far as the first and second degrees are concerned, is in part no doubt derived from the ceremonies of the early Operative Guilds."

The Operative Masons afterwards decided, that copies of their first and second O.B.s and Charges might be communicated to Bro. Simpson, and also to Bro. Sadler, the Librarian of the Grand Lodge of England.

The Oath of Nimrod, which belongs to the first degree, is as follows:—

THE WORSHIPFUL SOCIETY OF FREE MASONS.

Oath of Nimrod.

Apprentice Degree (1st).

I.....do, in the presence of El Shaddai and of this Worshipful assembly of Free Masons, Rough Masons, Wallers, Slaters, Paviers, Plaisterers and Bricklayers, promise and declare that I will not at any time hereafter, by any act or circumstance whatsoever, directly or indirectly, write, print, cut, mark, publish, discover, reveal, or make known, any part or parts of the trade secrets, privileges, or counsels of the Worshipful Fraternity or Fellowship of Free Masonry, which I may have known at any time, or at any time hereafter shall be made known unto me.

The penalty for breaking this great oath shall be the loss of my life.

That I shall be branded with the mark of the Traitor and slain according to ancient custom by being "throat-alled," my body buried in the rough sands of the seatwice in the twenty four hours so that my soul have no rest by night or by day.

Given under my hand and sealed with my lips thisday of.....

So help me El Shaddai and the holy contents of this book.

The First Master Mason. Take good heed to keep it right well for it is perilous and great danger for a man to forswear himself upon the holy book.

It will be observed that the "mark of the Traitor" is mentioned, and full details of this mark are given in my note in the 1910-11 Transactions of the Lodge, p. 75.

Another point of interest in this O.B. is the reference to the soul having no rest. The Operative tradition teaches, that unless a body be properly buried in peace, with the proper ceremony according to the rank of the Mason, that the soul will have no rest by night or by day, and this has always been regarded as a terrible punishment for any Mason.

The following Charge is then delivered to the Apprentice by the First Master Mason, and it must be signed by the new Apprentice.

THE WORSHIPFUL SOCIETY OF FREE MASONS,
ROUGH MASONS, WALLERS, SLATERS, PAVIORS,
PLAISTERERS AND BRICKLAYERS.

*Ancient Charge to the Apprentice to the Craft of
Free Mason.*

- (I.) You shall truly honour El Shaddai and his holy Church, the King, your Master and Warden. You shall not absent yourself but with the Licence of one or both of them, from their Service by Day or Night.
- (II.) You shall not Purloyn or Steal, or be Privy or Accessory to the Purloining or Stealing to the value of Six-pence from them or either of them.
- (III.) You shall not commit Adultery or Fornication in the House of your Master, with his Wife, Daughter or Maid.
- (IV.) You shall not disclose your Master's or Warden's Secrets or Councils which they have reported unto you, or what is to be concealed, spoken or done within the Privities of their House, by them, or either of them, or by any Free Mason.
- (V.) You shall not maintain any disobedient Argument with your Master, Warden or any Free Mason.
- (VI.) You shall reverently behave yourself towards all Free Masons, using neither Cards, Dice, nor any other unlawful games. Christmas time excepted.
- (VII.) You shall not haunt, nor frequent any Taverns, or Ale-houses, or so much as go into any of them, except it be upon your Master or your Warden, their or any of their Affairs, or with their or one of their consents.

- (VIII.) You shall not commit Adultery or Fornication in any man's House where you shall be at Table or at Work.
- (IX.) You shall not marry, or contract yourself to any woman during your Apprenticeship.
- (X.) You shall not steal any man's Goods, but especially your Master's or any of his Fellow-Masons, nor suffer any to steal their Goods, but shall hinder the Felon, if you can; and if you cannot, then you shall acquaint the said Master and his Fellows presently.

All these Articles and Charges which I have now recited unto you, you shall well and truly observe, perform and keep to the best of your Power and Knowledge.

So help you El Shaddai, and the true and holy Contents of this Book.

Given, under my hand, and sealed with my lips thisday of....., 191...

(Signed).....

Previous to the year 1663 it appears, from the old records, that boys of twelve or thirteen years of age could be Apprenticed to the Craft of Free Mason, and they were consequently "out of their time" at nineteen or twenty years of age, and in some instances they were passed as Fellows of the Craft before they were of full age.

It must here be made quite clear that the second, or Fellow's degree, is the lowest "within the Craft," the Apprentice who serves his seven years not being a Free

of Free Masons, Rough Masons, Wallers, Slaters, Paviers, Plaisterers, and Bricklayers here present, promise and declare,

That I will not at any time hereafter by any act or circumstance whatsoever, directly or indirectly, publish, discover, reveal or make known any of the secrets, privities or Councils of the Fellows of the Craft of Free Mason, which at this time, or at any time hereafter shall be made known unto me.

That I will not permit or suffer any labourer to be employed in the proper work of Free Masonry.

That I will not work with those that are not free.

That I will not teach labourers and unaccepted Masons, as I would teach Apprentices to, or Fellows of, the Craft of Free Mason.

I further promise and declare

That I will strictly preserve the honour of all Free Masons of whatsoever degree.

That I will not commit Adultery or Fornication with the Wife, Daughter or Maid of any Free Mason.

That the penalty for breaking this great oath shall be the loss of my life.

That I shall be branded with the mark of the Traitor and slain according to ancient custom

Given under my hand and sealed with my lips twice, this.....day of.....191...

(Signed)

So help me El Shaddai and the holy contents of this book.

The Charge which is recited to the Fellow of the Craft of Free Mason was revised and re-written by

“ Robert Padgett, Clearke to the Worshipful Society of the Free-Masons of the City of London in the second year of the Raigne of our most Gracious Sovereign Lord King James the Second of England 1686,” and is signed by him for the use of all the eight divisions of the Society.

You having been passed to the honourable degree of Fellow of the Craft of Free Mason I am to admonish you as here followeth—

- (I.) You shall honour El Shaddai and his holy Church; that you use no Heresy, Schism nor Error in your Undertakings, or discredit wise Men’s Teachings.
- (II.) You shall be true to our Sovereign Lord the King, his Heirs and lawful Successors; committing no Treason, Misprision of Treason, or Felony; and if any Man shall commit Treason that you know of, you shall forthwith give Notice thereof to his Majesty, his Privy Councillors, or some other Person that hath Commission to enquire thereof.
- (III.) You shall be true to your Fellows and Brethren of the Science of Masonry, and do unto them as you would be done unto.
- (IV.) You shall keep Secret the obscure and intricate Parts of the Science, not disclosing them to any but such as study and use the same.
- (V.) You shall do your Work truly and faithfully, endeavouring the Profit and Advantage of him that is Owner of the said Work.

- (VI.) You shall call Masons your Fellows and Brethren, without Addition of Knaves, or other bad Language.
- (VII.) You shall not take your Neighbour's Wife villainously, nor his Daughter, nor his Maid nor his Servant, to use ungodly.
- (VIII.) You shall not carnally lye with any Woman that is belonging to the House where you are at Table.
- (IX.) You shall truly pay for your Meat and Drink, where you are at Table.
- (X.) You shall not undertake any Man's Work, knowing yourself unable or unexpert to perform and effect the same, that no Discredit or Aspersion may be imputed to the Science, or the Lord or Owner of the said Work be any wise prejudiced.
- (XI.) You shall not take any Work to do at excessive or unreasonable Rates, to deceive the Owner thereof, but so as he may be truly and faithfully served with his own goods.
- (XII.) You shall so take your Work, that thereby you may live honestly, and pay your Fellows the Wages as the Science doth require.
- (XIII.) You shall not supplant any of your Fellows of their Work, (that is to say) if he or any of them hath or have taken any Work upon him or them, or he or they stand Master or Masters of any Lord or Owner's Work, that you shall not put him or them out from the said Work, although you perceive him or them unable to finish the same.
- (XIV.) You shall not take any Apprentice to serve you in the said Science of Masonry, under the Term

of Seven Years; nor any but such as are descended of good and honest Parentage, that no Scandal may be imputed to the Science of Masonry.

- (XV.) You shall not take upon you to make any one Mason, without the Privity or Consent of six, or five at least of your Fellows, and not but such as is Freeborn, and whose Parents live in good Fame and Name, and that hath his right and perfect Limbs, and able of Body to attend the said Science.
- (XVI.) You shall not pay any of your Fellows more Money than he or they have deserved, that you be not deceived by slight or false Working, and the Owner thereof much wronged.
- (XVII.) You shall not slander any of your Fellows behind their Backs, to impair their Temporal Estate or good name.
- (XVIII.) You shall not, without very urgent Cause, answer your Fellow doggedly or ungodly, but as becomes a loving Brother in the said Science.
- (XIX.) You shall duly reverence your Fellows, that the Bond of Charity and Mutual Love may continue stedfast and stable amongst you.
- (XX.) You shall not (except in Christmas time) use any lawless Games, as Dice, Cards, or such like.
- (XXI.) You shall not frequent any Houses of Bawdery, or be a Pander to any of your Fellows or others, which will be a great Scandal to the Science.
- (XXII.) You shall not go out to drink by Night, or if Occasion happen that you must go, you shall

not stay past Eight of the Clock, having some of your Fellows, or one at the least, to bear you Witness of the honest Place you were in, and your good Behaviour, to avoid Scandal.

- (XXIII.) You shall come to the Yearly Assembly, if you know where it is kept, being within Ten Miles of the Place of your Abode, submitting yourself to the Censure of your Fellows, wherein you have transgressed, to make satisfaction, or else to defend by Order of the King's Laws.
- (XXIV.) You shall not make any Mould, Square, or Rule to mould Stones withal, but such as are allowed by the Fraternity.
- (XXV.) You shall set Strangers at Work, having Employment for them, at least a Fortnight, and pay them their Wages truly, and if you want Work for them, then you shall relieve them with Money to defray their reasonable Charges to the next Lodge.
- (XXVI.) You shall truly attend your Work, and truly end the same, whether it be Task or Journey-Work, if you may have the Payment and Wages according to your Agreement made with the Master or Owner thereof.

All these Articles and Charges, which I have now recited unto you, you shall well and truly observe, perform and keep to the best of your Power and Knowledge. So help you El Shaddai, and the true and holy Contents of this Book.

Reference to the Book of Constitutions issued by the Grand Lodge of England will shew, that several of the regulations which are contained in the Operative Charges are to be found in that book, pages 3 to 15. It is also important to observe page 7, that

“In antient times no brother, however skilled in the craft, was called a master-mason until he had been elected into the chair of a Lodge.”

This is also the Operative practice to this day.

THE FOUNDATION CEREMONY.

This ceremony is carried out once a year at the time of the Jewish Passover, that being the time when Solomon laid the foundation of the Temple.

The reading of I. Kings vi. 1, by the Lodge Chaplain, leaves no doubt as to the work upon which the Masons are engaged:—

“And it came to pass in the four hundred and eightieth year after the children of Israel were come out of Egypt, in the fourth year of Solomon’s reign over Israel, in the month Zif, which is the second month, that he began to build the house of the Lord.”

The question is sometimes asked, Why do you lay the first or foundation-stone in the North-East part of the building? The reason the ancient Masons give, is to obtain the best possible light for the fixing of the four great corner-stones of the building.

At 6 o’clock in the morning Grand Master Mason Solomon began to lay the great North-East corner footing stone, because at that time the sun-light was at the outside of the N.E. corner stone. That stone having

been "well and truly laid to the land-lines," he proceeded at 10 o'clock to the South-East corner and laid the S.E. corner stone as the sun at that time was shining at that corner. After refreshments, he proceeded to the South-West corner and there laid the S.W. corner footing stone at 2 o'clock, by which time the sun was shining from the South-West, and finally about 5 o'clock he proceeded to the North-West corner and laid the N.W. corner stone. Thus it will be seen that the course of the sun was the reason why they commenced the Temple at the N.E. corner and worked round to the North-West. The four corners being thus "fixed," the work of laying all the intermediate "Footing stones" was carried out by Passed Masters or members of the sixth degree.

Many Brethren present will remember, that when the foundation-stone of this Hall was laid, money was placed under the stone, but it is no secret that in ancient times, and in the Operative ceremony to this day a man formed the human sacrifice, the belief being that a man must be placed under the centre and four corners of the building, or it will not stand.

About thirty-nine years ago, when the writer was informed that he had been selected to be the human sacrifice on the next occasion, he naturally began to wonder how heavy the stone would be and how soon the weight would be removed.

To illustrate the ceremony, a table six feet in length is draped in white, and looks exactly like a large block of white stone, and at the time of the laying of the stone, six men lift the block and lower it over the "sacrifice," and the ceremony of testing the stone with square, level and plumb-rule proceeds in the ordinary way. It is extremely interesting to the "sacrifice" to sit still under

the stone and hear that the loss of his life has made the building strong, so that it will stand firm for ever.

At the conclusion of the ceremony and during the time that the Masons cease labour and go to refreshment, the "sacrifice" finds his way out, and goes home, being no more seen that day.

THE COMMEMORATION CEREMONY.

In the first place it must be made clear that in an Operative Lodge or Assembly three Masters rule jointly, and without the three are present, it is impossible to open a Master Mason's Lodge in the Seventh degree. Nothing can be done unless the three do meet and agree.

The First Master, who represents King S., and the Second Master, who represents H. of T., hold office for life or until they retire, but the Third Master who represents H. A., the Prince of Free Masons, only holds office for one year, commencing on the 2nd of October.

In my former Paper, Transactions 1909-10, p. 85, it was shown very clearly, that the method of changing the Third Master each year, is exactly the same as that which took place, we believe, on October 2nd in the days of Solomon.

That is, the Third Master never resigns or gives up his office, but is always slain, hence the ceremony is a "Commemoration." The annexed notice gives the times.

THE WORSHIPFUL SOCIETY OF FREE MASONS,
ROUGH MASONS, WALLERS, SLATERS, PAVIORS,
PLAISTERERS AND BRICKLAYERS.

General Notice. All Divisions.

The Annual General Assembly will take place on Monday, 2nd October, at 12 noon.

- 11.45 a.m. Commence to open VII degree.
- 11.58 a.m. VII declared open.
- 12.00 noon. Grand Master's Salute to El Shaddai.
- 12.1 p.m. Open in IV degree (on site of Temple).
- 12.4 p.m. Call off for refreshment.
- About 12.20 p.m. The 3rd Master Mason is Slain.
- About 12.45 p.m. The 3rd Master Mason is not found.
- 1.4 p.m. Summon a muster of all Workmen
(three not there).
- About 1.30 p.m. Found, Slain.
- 3.0 p.m. Commence to install new 3rd Master
Mason VII degree.
- 5.0 p.m. Call off for 30 minutes.
- 5.30 p.m. Open in V degree. Appoint Officers,
and other work.
- 8.15 p.m. The Masters, if they think fit, may
"call off" for 15 minutes.
- 9.0 p.m. Commence to close in all seven degrees.
- 10.0 p.m. Tyler's Song.

It will be seen that the work which the Third Master has to undertake is both long and difficult, and no man over sixty years of age is expected to carry it out. The writer is over this age limit, and therefore has no fear of being again called upon.

The arms of the Society illustrate the tomb which we are taught King Solomon ordered for his Third Master Mason, and into which the Third Master is placed each year on 2nd October.

THE DEDICATION CEREMONY.

The Operative system teaches that King Solomon dedicated the Temple on 30th October, and that day is the one on which this ceremony takes place.

THE WORSHIPFUL SOCIETY OF FREE MASONS,
ROUGH MASONS, WALLERS, SLATERS, PAVIORS,
PLAISTERERS AND BRICKLAYERS.

General Notice. All Divisions.

The Annual General Assembly in Commemoration of the Dedication of the Temple will take place on Monday, 30th October, 1911, at 12 noon.

- 5.45 a.m. Commence to open VII degree.
- 5.58 a.m. VII degree declared open.
- 6.00 a.m. The Masters see the rising sun in the East.
Salute to El Shaddai.
- 6.10 a.m. Commence the fixing of the North-East
Corner head-stone.
- 6.10 a.m. Commence the fixing of the Key-stone of
the Sacred Arch.
- 10.45 a.m. The work is completed. Cease Labour.
- 12.00 noon. The Grand Masters' salute to El Shaddai.
- 12.01 p.m. Commence the Dedication of the Temple.
- 4.00 p.m. Call off for thirty minutes.
- 4.30 p.m. Dedication ceremony resumed.
- 6.00 p.m. Dedication completed. Commence to close
in all seven degrees.

(For details of ceremony see I Kings viii. 27, etc.,
II Chronicles vi. 2.)

- 6.30 p.m. The Feast.
(See I Kings ix. 65.)
- 10.00 p.m. The Tyler's Song.

The Dedication Ceremony which the Operatives still use was re-written by "Robert Padgett the Clearke to the Society" in 1686, and is practically the same as that used at the Dedication of the new Masonic Hall. It will

be seen that the Ceremony is of great length and commences at 5.45 a.m., but since the year 1686 Master Masons over sixty years of age are not required to be present until 10.45 to see the work of the Temple completed.

THE MASTERS' THRONE.

In all the ancient Building Guilds and Masons' Companies, in all parts of the world, the Three Masters are always placed in the west, so that they may see the rising sun in the east. An official is placed in the north to watch the sun at its meridian, and another officer sits in the east, so that he can watch the sun set in the west.

To ascend to the Master's throne there are seven steps, each step representing a science; commencing at the foot, the first one is Grammar, followed by Rhetorick, Logick, Arithmetic, Geometry, Music, the top step being Astronomy. On the 2nd of October the Third Master Elect must ascend the seven steps upon his bare knees, and answer questions on each science, before he may be placed in the Third Chair. He must prove that he is "filled with wisdom and understanding, and cunning to work" as did H. A. whom King Solomon obtained from the King of Tyre.

To assist the Third Master to rise up the seven steps, he has the help of the double grip of a Master Mason, and without that help it would not be possible for a person to mount the steps leading to "the seats of the mighty," as the throne in the VIIth degree is technically termed.

THE SWASTIKA.

Now we come to the consideration of the Swastika, which is the most interesting and most important part of the subject.

The full details are only made known to a Mason who has attained to the rank of Master Mason VIIth degree.

The Operative Free Masons explain this emblem in a lecture to a newly enthroned Third Master Mason, on the one day in the year, 2nd October, and as the details require fully seventy minutes to make clear, it follows that only a short summary can be given.

The Swastika is the very oldest known sign of The Great Architect of the Universe. It is very closely connected with the ancient belief that the Pole Star is the centre of all things, the seat or home of God himself.

From the Pole Star, the Operative lecture tells, that a Plumb-line comes down to the centre of a Mason's Lodge, and under that centre is formed the Swastika. The Swastika is made in nine parts and may be of any size, "even as wide as the universe."

When it is laid down on the square with the blue side upwards, and going with the sun, it represents The Great Architect, Life, and all that is good, but when reversed, with the black side upwards and going against the sun, it means Evil, Death, and all that is bad.

It will be noticed, that the Swastika in gold which the Operatives presented to me when I attained to the Third Chair is in the "Life" position.

This symbol, we are told in the lecture, was first known to the Turanian Masons, who are said to have lived long before the Babylonian Empire. They are the earliest known builders and were a yellow race, who

spread and carried their Craft from Central Asia to China, India and Egypt.

The Etruscans became great builders, and the Craft was handed on to the Romans, and it was through the Roman Collegia that the Science was brought to Britain.

The ancient scrolls and charges inform us that as long ago as 926 King Athelstan "loved well Masons and granted them a Charter," and they held an assembly at York.

The Athelstan Charter, granted nearly a thousand years ago, is regarded by The Worshipful Society of Free Masons as the foundation upon which their Craft rests in England.

A large quantity of old Craft information, including details of the ritual, is still preserved in the Turanian cipher, and the key to that cipher is an angle of 90 degrees formed by the 3·4·5 angle of a Master's Square. This fact is important, as it connects the earliest known builders with the Operative Craft of the present day, and shews the value of the Square to a Master, which is shewn to be one of the four angles of the Swastika, the mark of the Great Architect of the Universe.

The Book, "The Builders' Jewel," now exhibited, was published in 1757, and contains practical rules for Operative Builders; it contains also details of the five noble orders of Architecture, Tuscan, Dorick, Ionick, Corinthian and Composite. The book is the property of an Operative Lodge and has been specially lent for inspection.

In conclusion, the writer hopes that although this Paper only touches the fringe of the subject, that enough has been said to prove, that there is much more in Freemasonry than many persons think, and that there is ample scope for those who will investigate, and send the results of their work to the Lodge of Research.

On the conclusion of the reading a hearty Vote of Thanks was accorded to Bro. STRETTON.

Bros. THORP, S. PERKINS PICK and the Rev. W. W. COVEY CRUMP discussed several points mentioned in the Paper.

The SECRETARY was requested to forward on behalf of the Brethren a letter of condolence and sympathy to the W.M. ELECT, on the death of his son.

Bro. THORP referred in feeling terms to the death of the late Bro. W. J. HUGHAN.

The SECRETARY was requested to forward a letter of condolence to Mrs. HUGHAN, expressing our deep sense of the loss sustained, our sincere appreciation of his work, and sympathy with her in her bereavement.

A letter from Bro. W. H. STAYNES, P.M., resigning his membership, was recorded with regret.

The following Brethren sent apologies for non-attendance, viz. :—

Bros. Rev. C. T. MOORE, W.M. Elect; J. ELSTON CAWTHORN (Sherburn, near Leeds); J. C. MOOR (Sunderland); Rev. H. S. BIGGS, P.M.; CHARLES S. BURDON (London); J. A. SHERREN (Weymouth); F. W. CROSS (Walsall); G. W. BAIN (Sunderland); R. W. STRICKLAND (Northampton); JOS. WOOD (Yatton); G. DAVID POTTS, P.M.; W. LONNON (Portsmouth); R. C. LEVERSEDGE (Bath); J. EASTWOOD PICKARD, I.G.; W. A. GAYNER (Bath); T. J. RALLING (Colchester); J. RUSSELL FREARS, P.M.; F. HUGHES (Handsworth); THOS. JORDAN (Derby); C. W. FRANCIS (Birmingham); Dr. W. HAMMOND (Liskeard); S. R. BASKETT (Dorchester); C. F. OLIVER, J.W.; H. HARRIS.

Hearty Good Wishes were tendered by the Visiting Brethren, and the Lodge was closed.

The usual Conversazione was abandoned.

The "British" Lodge.

No. 334 Capetown.

This old South African Lodge has just celebrated its Centenary Festival, the Warrant being dated August 9th, 1811, and the Brethren have issued a very handsome and interesting brochure to commemorate the event.

From the very excellent reproduction of the Warrant given therein, it is interesting to note that it was issued under the authority of the Acting Grand Master of the Grand Lodge of England, Francis Rawdon Hastings, Earl of Moira, a worthy Mason of this our County of Leicestershire, with whose private virtues, zeal for Freemasonry and splendid services to the State, the members of the Lodge of Research have been from time to time reminded in the Transactions of the Lodge.

The prosperity of the "British" Lodge seems to have been continuous, and many Brethren distinguished in the Craft, or in the public service, have had their names placed on the Lodge roll.

Curiously enough, I have in my collection of Masonic relics a Certificate issued in 1831 by the "British" Lodge—then No. 637—to an initiate of the Lodge, and I have posted a copy of it to the Brethren, for preservation in their archives.

As the document is a specimen of the rare "Harper" Certificate, issued in blank by Thomas Harper, of Fleet Street, London, in the early part of last century—at one time common, but now rare—I have added a reproduction

and transcript of it to this Note. The Certificate is printed from an engraved plate, and so drawn up that it could be used by any Lodge, by simply inscribing its name on the ribbon at the top, as has been done in this case.

The Certificate reads as follows:—*

BRITISH LODGE 637 CAPE OF GOOD HOPE.

These are to Certify

That Brother *Jacob Toby, Mariner* was at the age of 21 Years, regularly and duly initiated into the Mysteries of Masonry, in this Lodge, on the 17 day of *January 1831* & having found him to be a worthy Brother we recommend him as such to all Masons and Lodges, to be received after due Examination.

To this Certificate, the said Brother, has in our presence Signed his Name in the Margin. In testimony whereof we have subscribed our Names in open Lodge, this 17th day of *Jany. A.L. 5831 A.D. 1831.*

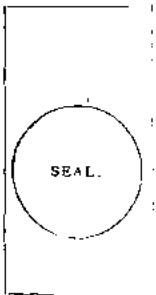

<i>Morris Sloman.</i>	W.M.
<i>Thomas King.</i>	S.W.
<i>J. D. Gregory.</i>	J.W.
<i>Bayly Dyason.</i>	Secr.y

Description of the above named.....
 Age.....Profession or trade.....born in.....
 ...Feet high.....Hair.....Eyes.....Nose.....Complexion.

* *Vide* Plate II.

The foregoing Certificate is parchment, $13\frac{1}{2} \times 9\frac{1}{2}$ inches in size, and although very yellow and discoloured with age, the words are quite legible. There is a red wax Seal on light blue ribbon attached to the document; the device on the Seal is the letter G in a triangle surrounded by the words BRITISH LODGE OF AFRICA.

The personal description at the foot of the Certificate is left blank in this case. When filled up it would prevent the Voucher being readily used by any one into whose possession it might come, and prove most useful to Lodges at seaports and other places, frequently visited by travelling impostors.

The recipient, Jacob Toby, aged 21, Mariner, like all mariners, was a bird of passage. His Certificate records that he was initiated on January 17th, 1831, and as it was signed in open Lodge on the same day by the officers and the recipient, it is a fair assumption that a favorable breeze necessitated his immediate departure from the Cape. For this reason a Certificate of his initiation only could be granted to him, and so, with this interesting and to him valuable document, away he sailed.

Whether Toby returned to the "British" Lodge for his other two degrees, I do not know; if he did, the Minute-book would contain a record. It is, however, quite certain that he took the degrees somewhere, for on the back of the Certificate is the following French endorsement, notifying his affiliation as a Master Mason to a French Lodge at Port Louis in the Island of Mauritius.—

"Affilié à la R. : L. □ de St. : Jean S. : L. : T. : D. : de la Triple Esperance reg. : Const. : S. : les auspices du Gr. : Or. : de France. Or. : du Port Louis Ile

Maurice le 5^e J. : du 11e M. : de l'an de la V. : Lum. :
5836.

Par mandement de la L. :

Grumpf (?)

secret. : m. Ecc.

S. : P. : R. : +."

[TRANSLATION.]

"Joined the Worshipful Lodge of St. John, under the distinguishing title of 'Triple Hope,' regularly constituted under the authority of the Grand Orient of France, at Port Louis, Isle of Mauritius, the 5th day of the 11th month of the year 5836 of the true light."

In addition to Toby's "British" Lodge Certificate, I have also a Certificate issued to him by the Lodge "Triple Esperance," on his affiliation to it, according to the foregoing endorsement. It is a handsome parchment of a usual French type, printed from an engraved plate, depicting temple, two pillars, figures of Faith, Hope, Wisdom and Strength, pyramids, trees, working-tools, etc. It is signed by Toby and by twenty officers and members of the Lodge, among which are three English names, viz. :—

A. G. Barnes, S. : P. : R. : C. :, M. : Cerem. :

J. Ormsby, S. : P. : R. : C. :

C. H. Cooper, M. :

The document states that Toby possesses the third degree of symbolic masonry, and is dated the 7th day of the 11th month of the year 5836 of the true light, which corresponds to January 11th, A.D. 1837.

The Seal of the Lodge in red wax is attached to the Certificate by light blue ribbon, and enclosed in a tin box.

The two documents described in this Note are an interesting pair, and show the cosmopolitan character of Freemasonry.

J. T. T.



The One Hundred-and-First Meeting

of the Lodge was held at the Freemasons' Hall, Leicester, on Monday, November 27th, 1911. The Worshipful Master, Bro. GEORGE BONNER, P.P.G.Std.B., presided.

The Minutes of the last regular Meeting were read and confirmed.

The following sixteen Brethren and one Lodge were elected members of the Correspondence Circle of the Lodge, viz. :—

- 738. UNITED SERVICE LODGE, No. 24 British Columbia.
- 739. Bro. J. LEVY, P.M. —, P.P.J.G.W. Notts.
- 740. Bro. H. N. ORMSBY, 1367 Malvern Transvaal; 2653 Springs Transvaal.
- 741. Bro. ALFD. R. PERKINS, I.P.M. 3433 Shwobo; 2219 Mandalay; 2904 Maymyo; 3464 Chester; 832 Rangoon; D.G.A.D.C. Burma.
- 742. Bro. DAVID INNES SMITH, P.M. 2219 Mandalay.
- 743. Bro. CHAS. JOHN GALE, W.M. 2219 Mandalay.

744. Bro. RAMASWAMI GOPOLA AIYENGAR, 2219 Mandalay.
745. Bro. THAKUR PRASAD, 2219 Mandalay.
746. Bro. VELLORE VRASAMI NOVADU, 2219 Mandalay.
747. Bro. W. C. CLOVER, I.P.M. 2028 Narborough.
748. Bro. JOHN GEORGE WEBSTER BOULTON, P.M. 2028 Narborough.
749. Bro. HOWARD SPOONER, P.P.G. Treas., Staffs.
750. Bro. W. F. BROCKBANK, P.P.G.R., E. Lanes.
751. Bro. Capt. M. S. HEWETT, J.W. 563 Umballa.
752. Bro. C. C. GILL, P.M. 53; W.M. 379 Bath; Prov. G. Sec. Somerset.
753. Bro. ARTHUR MARKHAM, 2865; J.D. 1754 Penarth.

The SECRETARY communicated a message from the W.M. Elect, asking to be excused from taking office this Session. The W.M. expressed the regret of the Brethren.

The W.M. invested the following Officers, absent from the last Meeting, viz. :—

D.C.	Bro. W. A. LEA, P.M.
I.G.	Bro. J. EASTWOOD PICKARD.

Bro. S. PERKINS PICK gave a most interesting extempore Address on

THE COMACINES,

tracing their origin, history, work and influence, and quoting numerous passages from books in confirmation. It is hoped that a short resumé will appear later in the present volume.

Bro. J. T. THORP, P.M., read the following Paper:—

Lodge No. 94 at the Ben Jonson's Head.

By Bro. JOHN T. THORP, P.M., etc.

For fifty years after the establishment of the Grand Lodge of England in 1717, difficulties continually arose between the Grand Lodge and its daughter Lodges. The records of the Grand Lodge contain many references to "irregular making of Masons," absence from the Communications of the Grand Lodge, refusal to recognise its authority, non-payment of dues, quarrels, contentions, erasure of Lodges, with consequent ill-feeling and bad blood.

Probably some of the difficulties were due to the individual Lodges having at one time been wholly independent of any authority, each a law unto itself, while later, the advent of the Ancients with their claim for adherence to the old Landmarks, caused much trouble and disruption.

It is not well, perhaps, to dwell too much upon this feature of early 18th century Freemasonry, but I wish to call attention to a Lodge, which, in 1755, had a serious quarrel with the Grand Lodge, and was erased from the roll in consequence. This was Lodge No. 94, meeting at the Ben Jonson's Head in Pelham Street, Spitalfields, London.

The account of the incident appears briefly in the publications of both Grand Lodges.

In the 1756 Book of Constitutions of the original Grand Lodge, we read:—

“GRAND LODGE, at the *Devil Tavern* aforesaid, was held on *March 20, 1755*. . . . The GRAND LODGE then took into Consideration, a Complaint against certain Brethren for Forming and Assembling under the Denomination of a Lodge of *ancient Masons*, who, as such, consider themselves as independent of this Society, and not subject to our Laws, or to the Authority of our GRAND MASTER. . . . The Question being put, That the Meeting of any Brethren of this Society, as, or under any Denomination of *Masons*, other than as Brethren of this our ancient and honourable Society of FREE and ACCEPTED MASONS, is inconsistent with the Honour and Interest of the CRAFT, and a high Insult on our GRAND MASTER, and the *whole Body* of MASONS: It was carried in the Affirmative; ONE of the Brethren, complained of, only dissenting.”

“The *Deputy Grand Master*, in his great Clemency, then moved, That the Consideration of the irregular Proceedings of the said Brethren, might be postponed till next *Quarterly Communication*, hoping that a thorough Sense of their Misconduct, and a Determination not to

be guilty of the like for the future would then appear, and reconcile them to the *Grand Lodge*; and agreed to."

"GRAND LODGE, at the *Devil Tavern* aforesaid, was held on *July 24, 1755*, in ample Form. . . . Ordered, That, the Brethren, complained of at the last *Quarterly Communication*, persisting in their Disobedience to the Determination of the GRAND LODGE, their Lodge, No. 94, held at the *Ben Johnson's* (sic) *Head* in *Pelham-Street, Spital-Fields*, be erased from the Book of Lodges; and that such of the Brethren thereof, who shall continue these irregular Meetings, be not admitted as Visitors in any Lodge."

The Lodge was therefore erased.

This same incident is recorded as follows by Laurence Dermott in *Ahiman Rezon*, 1787, pp. xvi.-xviii.

"In the aforesaid Calendar,* amongst other things which I am to suppose were extracted from the records of modern Masons, I observed a censure passed (in the year 1755) on persons for calling themselves Ancient Masons."

"The compiler seems to be unacquainted with the masonical proceedings of that time, otherwise he would have known that the persons were censured, not for assembling under the denomination of Ancient Masons, but for practising Ancient Masonry, having their constitution from the Modern Grand Lodge. The case was briefly thus: A Lodge at the Ben Jonson's Head in Pelham Street, in Spitalfields, were (sic) composed mostly of Ancient Masons, tho' under the Modern Constitution.

* The Calendar issued in 1777 by the Grand Lodge of England (Moderns).—ED.

Some of them had been abroad, and received extraordinary benefits on account of Ancient Masonry. Therefore they agreed to practise Ancient Masonry on every third Lodge night. Upon one of these nights some Modern Masons attempted to visit them, but were refused admittance: the persons so refused laid a formal complaint before the Modern Grand Lodge, then held at the Devil Tavern, near Temple-Bar. And the said Grand Lodge, though incapable of judging the propriety or impropriety of such refusal (not being Ancient Masons) ordered, that the Ben Johnson's (sic) lodge should admit all sorts of Masons without distinction."

"And upon non-compliance to that order, they were censured, &c."

"The persons thus censured, drew up, printed, and published, a Manifesto, and Masons Creed; (sold by Owen in Fleet-street) which did honour to their hearts, and heads."

.

"Every real—that is, every Ancient Mason, who had read those publications, were convinced of the injustice done to the Ben Johnson's (sic) lodge, in censuring them for doing their duty; a duty which they owed to God and to themselves; and a business which their judges (the then Modern Grand Lodge) were as ignorant of—as a blind man is in the art of mixing colours."

"Nevertheless censure was passed, and a minute thereof preserved in the archives of the (wou'd-be) Supreme, &c. From whence it is now published in their calendar as one of the legislative orders on their records, which records have received much honour and amendments from twelve-penny lectures, twelve-penny illustrations, and twelve-penny calenders."

“The brethren censured had their constitution from the Modern Grand Lodge, nor had they any connexion with the Ancient Grand Lodge at that time nor since; nevertheless I do affirm (from personal knowledge and public report) they were persons of most amiable characters as men and masons; and the names of the ingenious Marigeot, Cheetham, Cornish, &c. &c. will be long remembered with esteem and veneration, amongst the faithful and legitimate heirs of old Hiram.”

There came recently into my hands a copy of an old MS., consisting of the ritual worked in 1740 in the Lodge at the Ben Jonson's Head. This MS. was at one time the property of the famous Masonic writer Dr. George Oliver, at whose death it came into the possession of Bro. Richard Spencer, the Masonic Bookseller, etc., of London. In July, 1875, it was offered in London for sale by public auction, and was bought by Bro. W. J. Hughan for the Hon. R. F. Bower, of Keokuk, Iowa, who sent Bro. Hughan a verbatim copy of the MS. The original is now in the splendid Library belonging to the Grand Lodge of Iowa, and the copy that came into my hands was taken from Bro. Hughan's copy.

(The Apprentice Degree was read and explained, also part of the Fellow Craft's, but the Master's, being that conferred before the separation of the Royal Arch, was not read.)

It is impossible to print this MS., or even to give extracts therefrom, suffice it to say, that there are many similarities to the present familiar ceremonial, and also many

differences. The language used is simple and impressive, and in some parts it might even be considered more beautiful and more suitable than that now in general use. A few special features may however be mentioned, viz.:—Officers represent certain persons, whose names are given.—Frequent “operative” references.—Curious features in opening and closing.—No prayers.—Frequent use of passages of Scripture.—No penalty in O.Bs.—Due guard of E.A.—First and second words exchanged.

Bro. J. T. THORP, P.M., exhibited and described the following Masonic relics, viz.:—

(1.) A parchment Certificate issued in 1777 by St. George’s Lodge, No. 70 Berwick. A transcript follows.

“**We** the Master, Wardens, and Secretary, of the Lodge of St. George No. 70 Berwick. Do hereby Certify to all whom it may Concern that **John Bell** was regularly Entered an Apprentice, Passed Fellow Craft, and, as a Recompence due to his Zeal, Diligence and Capacity, **We** have raised him to the Degree of a Master Mason. **We** therefore, in the strongest manner, Recommend him to every Place of Trust in Masonry. And that all Regular Constituted Lodges in Ancient Masonry may receive him as a trusty and well beloved Brother, and Render him every Service as far as the Rules of Masonry direct. **Given** under

our Hands, and Seal of the Lodge, this 29th day of December in the year of our Lord One thousand seven hundred and seventy seven, and of Masonry 5777.

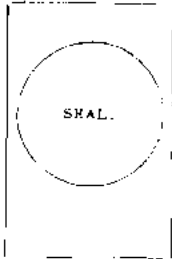

Henry Hammond. **Master.**
 James Vardy. **S^r Warden.**
 Richard Reavdy. **J^r Warden.**
 Thomas Liddell.
Secretary."

This Lodge was warranted in 1758 by the "Ancients" Grand Lodge of England to meet at the White Bear in Berwick on Tweed. At the Union in 1814 it was re-numbered 94, and, having ceased to meet, was erased from the roll in 1827. The Seal is red wax on light blue ribbon. The document is in excellent preservation.

(2.) A silver engraved Jewel, early 19th century, subsequently used for the top of a walking-stick. It contains the usual Craft, Arch and Templar emblems.

Nos. 1 and 2 were lent for exhibition by Bro. ALFRED GATES, of Sherborne.

(3.) A very handsome satin Apron, Masonic emblems embroidered in gold and colors thereon.

(4.) Gold and enamel oval Jewel, the usual Masonic emblems and the words "FRIENDSHIP & BENEVOLENCE."

(5.) Jewel of the Grand Stewards' Lodge; the following inscription engraved on the back "The Gift of J. Sadler Gale to his Friend & Brother Dr. Brown Mill as a small Token of sincere respect & regard, 4 Sep^r 1818."

Nos. 3-5 were formerly worn by Baron Brown Mill who was at one time physician to Louis XVIII. of France, who made him a Baron. He subsequently resided in Bath for many years, and was First Principal of the "Royal Cumberland" Chapter there in 1818. They were lent for exhibition by Bro. C. F. CALLAWAY of Bath.

A Vote of Thanks was passed to the Exhibitors.

The SECRETARY read a copy of letter from the Grand Secretary, authorizing removal of Lodge to Freemasons' Hall, Leicester.

It was resolved that a letter be sent to Mrs. Sadler, expressing the deep regret of the Brethren of this Lodge at the death of her husband, Bro. HENRY SADLER.

Bro. J. T. THORP reported the deaths of Bro. General S. C. LAWRENCE, of Boston, U.S.A., and Bro. GARDINER (Leeds).

The SECRETARY proposed and the TREASURER seconded Bro. FRANK HOWARD POCHIN, Hambleden, Knighton Road, Leicester, P.M. 2028, P.P.G.Std.B., as a Joining Member of this Lodge.

Apologies for non-attendance were received from Bros. R. C. LEVERSEDGE (Bath); G. W. BAIN (Sunderland); W. B. HEXTALL (London); T. C. BATES (Derby); J. A. SHERREN (Weymouth); W. LONNON

(Portsmouth); F. H. POCHIN (Leicester); T. J. RALLING (Colchester); H. G. BURROWS (London); C. L. EDWARDS (Loudwater); W. T. TOPOTT; H. G. MARRIOTT; C. F. OLIVER; J. F. SNAITH; H. HOWE; F. HUGHES (Handsworth); J. WARD; J. W. BARKER.

Hearty Good Wishes were tendered by the Visiting Brethren, and the Lodge was closed.

French Prisoners at Lanark.

By Bro. R. E. WALLACE-JAMES, P.M. 57 (S.C.).

The Members of the Lodge of Research, No. 2429, have, through the research of our Editor, Bro. Thorp, had particulars of many French Prisoners' Lodges, held at various places in England and Scotland, presented to them, the following short notice, therefore, of a Certificate granted by another Lodge of the same nature, held at Lanark, may not be devoid of interest.

French prisoners were, from about the year 1803 until the peace of 1814, confined at various places in Scotland—for instance, Edinburgh Castle, Greenlaw Depôt, Perth Depôt, Esk Mills and Valleyfield in Midlothian, and to a limited extent also at Dumbarton. But besides these places, many prisoners, principally officers and civilians, were detained on parole at Edinburgh, Dumfries, Melrose, Selkirk, Hawick, Jedburgh, Kelso, Biggar, Lockerbie, Peebles, Sanquhar, Lanark and some other towns. They lodged with private families in the towns and, though prisoners, they had in many cases a considerable amount of liberty, and it is remarkable that so small a number of them broke their parole. Nominally they were restricted to a radius of one mile from the centre of the respective towns, but in many cases they passed freely much beyond that narrow limit, and that often without the formality of special permission. The

French officers seem to have been, especially in Scotland, frequently entertained by the townsfolk and neighbouring gentry, and were on the whole apparently very good jovial fellows, and returned hospitality as occasion occurred.

Members of the Craft among them instituted Lodges in many towns and met regularly from time to time. Lanark being a large centre for their detention, it is not surprising that such a Lodge was formed there. Unfortunately we have not much information about their meetings, but stray writings occasionally come to light.

The following is a Transcript and Translation of a Diploma or Certificate granted to a Brother who was returning to France—either in exchange or in ill-health. The Certificate is on a large skin of parchment $23\frac{1}{2}$ inches by $15\frac{1}{2}$ inches in size—although the writing thereon only takes up 13×10 —and is written throughout, the words being still quite clear and legible. It is quite plain without any ornamentation whatever, but some of the signatures are very difficult to decipher on account of the peculiarity of the handwritings.

[TRANSCRIPT.]*

AU NOM ET SOUS LES AUSPICES DU G. O. DE FRANCE.

A toutes les  . Régulières.

UNION. ——— SALUT. ——— FORCE.

NOUS Vénéralble et Officiers de la Resp^{ble}  S^t
Jean sous le titre distinctif des *Amis réunis dans*
l'adversité, régulier^t assemblés en instance à L'O.:

* *Vide* Plate III.

des Officiers français sur parole à Lanark en Ecosse et réunis par les N. M. connus des Seuls V. M. Déclarons, Certifions et atestons que le T. C. F. *Maurice Schauenburg*, né à *Niederkerckheim* dép^t du haut Rhin, le 14 février 1784, adjud^t au 11^e Régiment de dragons, possède le troisième grade Symb. que son zèle & la pureté de ses mœurs l'ont fait chérir de tous ses FF. En foi de quoi nous lui avons donné le present Certificat, à la charge par lui de se faire reconnaître et réguliser à une L. Rég. aussitot après son retour en France, et pour que ced. Certificat ne puisse servir qu'audit f. Schauenburg, Nous lui avons fait apposer sa signature en marge, *Ne Varietur*, afin qu'il reçoive, Joie, bon accueil et Secours, s'il se trouvait dans le besoin, offrant le meme retour à chaque f. qui se presenterait de votre part. Fait et délivré dans un lieu très éclairé où règnent la Paix, le Silence et la Charité, le * jour du * mois de l'an de la V. L. 5812 répondant au 25 Décembre 1812 E.V.

Le 1^{er} Surv^t*Breton. M.*

Le Vén.

*Rumet.*Le 2^e Surv^t*Gaudet. M.*

De L'O. De La Rochelle. S. p. R. +. du Souv. chap. Chevalier de L'étoile O. de Versaille.
S^t Napoléon des Elèves de Mars,
O. du 4^e Rég^t L'inf^{te} Legère.

Schwick.

M. O. des amis de
l'honneur français
O. de l'Isle d'Elbe.

Par Mandem^t de la Resp^{bl}e L.*Ls. Rayneval. m. S^{re}*

De la parfaite Egalité O. de Mont Didier (Somme)
et des Chev. de S^t Jean d'Acre O. du 12^e d'Inf^{te} Legère.

B^{re} de Aldeiva. (?)

M.

*Monde. (?)**Rongeuil. (?) m. à l' O. de Calais.**Schwick.*

M. des amis réunis dans
L'Adversité, O. des Off^{rs}
Français sur parole à Lanark.

Signed in dexter margin.

*Ne Varietur.**Me Schauenburg.*

The One Hundred-and=Second Meeting

of the Lodge was held at the Freemasons' Hall, Leicester, on Monday, January 22nd, 1912. The Chair was occupied by the Worshipful Master, Bro. GEORGE BONNER, P.M. 523, P.P.G.Std.B. There was a good attendance of Members and Visitors.

The Minutes of the last Meeting were read and confirmed, and Bro. F. H. POCHIN, P.M. 2028, P.P.G.Std.B., was unanimously elected a Joining Member of the Lodge.

The following three Brethren were elected to Membership of the Correspondence Circle of the Lodge, viz. :—

- 754. Bro. EDGAR WALLEY, S.D. 3047 Leeds.
- 755. Bro. D. B. HALL, Sec. 3009 Chittagong, E. Bengal.
- 756. Bro. G. TREVELYAN LEE, W.M. 253 Derby.

The following Paper was read :—

History and Symbolism of the Third T.B.

By Bro. the Rev. W. W. COVEY CRUMP, P.M. 88
Cambridge; P.P.G.Chap. Cambs., etc.

- SYNOPSIS.—I. Existing Explanations of the Third T.B. imperfect—Why?—Connection of the R A. with Third Degree—Diverse views of former Grand Lodges—Connection as defined in 1813.
- II. Progressive symbolic teaching inculcated in the preceding Degrees—Continued in the Third Degree—Peculiar objects of research in this Degree—*Mors janua Vitæ*—Our only light that of Divine Revelation—The *Sanctum Sanctorum*—Porch, Dormer and Pavement—Life: present and future—Not Metempsychosis but persistence of Personality—Laws of Matter and Energy unaffected—Emblems of Mortality—Masonic initials depicted thereon, and the Hiramite tradition—Working Tools—Conclusion.
-

I.

When that daily advancement in Masonic knowledge, which is enjoined upon every initiate, has proceeded beyond a mere verbal accuracy in rendering our ceremonies, the Freemason's attention naturally turns to the three Tressel or "Tracing" Boards which lie open in the Lodge for the Brethren to moralise upon. It is upon them that the instruction peculiar to each Degree is delineated. They constitute invaluable charts of information touching the significance and symbolism of our Masonic system.

To thoroughly appreciate the symbolic teaching illustrated upon the Tracing Boards, we must carefully study the instruction in those time-honoured lectures which have to-day fallen almost into disuse. Still (though in a condensed and simplified form) that instruction, as far as the First and Second Degrees are concerned, is fairly contained in the accepted and authorized "Explanations" of the First and Second Tracing Boards with which most of us are familiar. But when the Masonic student attains to the Third Degree, and seeks for a similarly full "Explanation of the Third Tracing Board" to complete the series, he discovers that no such concise and formal compendium has been authorized, or is generally available. Why and whence is this omission?—he naturally asks. How is the absence of such an Explanation to be itself explained?

It will be readily obvious that if we are to ascertain the cause of this anomaly, it must be sought in the past history of the English Grand Lodge. And, although it is admittedly difficult to substantiate every detail by documentary evidence, I venture to put forth the following solution as fairly and mainly correct.

We are reminded by the word "United," forming part of the title "*United* Grand Lodge of England," that there was once a period when several Grand Lodges co-existed in England, between which sovereign bodies an unhappy rivalry and a mutual antipathy frequently prevailed. Besides disputes about each other's jurisdiction and derivation, serious differences long existed in regard to the position and constitution of the Holy R.A., which differences affect the subject before us now.

We may safely assume that the Master Mason's Degree in Freemasonry has had little (if any) connection with

a Third Degree in the Operative or Guild system; but it undoubtedly had a close connection with the R.A.—even as it still has to-day—though the nature of the connection may have varied from time to time, and it may never have been (as it certainly is not to-day) defined precisely.

Theoretically the R.A. is not itself a Degree, but is an integral part of the Third Degree in the Craft. Yet in the Third Degree Ceremony no reference is made to the existence of the R.A., and in practice the latter is conferred as a separate and entirely optional Degree. Thousands of English M.Ms.—accepting the assurance of the representative of K.S., that certain *substituted ss.* “shall serve to designate” them and all M.Ms. until time or circumstances restore the genuine ones—continue to accompany the Wardens in their quest for the *genuine ss.* of the M.M., oblivious of the fact that in the R.A. it is claimed that those *ss.* were long ago re-discovered, and are therein communicated.

Even apart from this, there is ample evidence that the present M.M.'s degree is in a sadly mutilated condition. Unfinished in its traditional history, and terminating abruptly in its symbolism, it leaves the mind waiting for something else—that deficiency being supplied in the R.A.

That the present R.A. Word was originally termed “the word of a Master Mason” is an indisputable fact, and easily explains why that word occurred on some of the 18th Century Tracing Boards of the Third Degree. Probably, as it became the prominent feature in its exalted surroundings, it was quietly and gradually eliminated from the Lodge work of the Third Degree.*

* Hughan: *Origin of Eng. Rite*, p. 92 (ed. of 1909).

Another collateral fact to be borne in mind is, that the custom of conferring the Third Degree in private Lodges (until 1725 it was only conferred in Grand Lodge), and upon Fellowcrafts who had not attained to the Master's chair, was a custom which gradually came into vogue about the same time as the development of the R.A. During many years after 1725 the Third Degree was worked only occasionally, and was usually regarded as of an optional nature, a Fellowcraft frequently being Master of a Lodge and ruling it on ordinary occasions as a *primus inter pares*.

From the foregoing brief evidence it would appear that at the Union of the so-called "Atholls" with the "Moderns," the conflicting views of these Grand Lodges had to be reconciled, and their respective Tracing Boards for the Third Degree had to be brought more closely into line, although I am unaware that any attempt was made to prescribe a rigid uniformity in the matter. If such an attempt was ever made its effect was only ephemeral, and even since the Union (in 1813) various minor alterations in the T.B. emblems have been sporadically introduced (not always for the better), some details have been added, others have quietly dropped out, and variations exist still between Tracing Boards supplied by different Masonic furnishing firms. These things ought not so to be, but so they are. And, until the relation of the R.A. to the Master Mason's degree has been more clearly and accurately defined, it seems useless to look for a final and authoritative determination as to the emblems which should properly constitute its Tracing Board. Hence it must also remain impossible to satisfactorily and conclusively explain all the symbolism of the present Third T.B.,

especially to those who are unacquainted with R.A. mysteries.

Let us now turn aside from the subject of the connection between the Third T.B. and the R.A., to consider another connection (though one of a very different kind) which calls for careful attention. Let us ask what connection exists between the Third T.B. and its analogous companions in the preceding Degrees.

At the outset of the Third Degree Lecture we are reminded that "every Degree in Freemasonry is progressive." Accordingly all work in the Lodge regularly proceeds *from* the First, *through* the Second, *to* the Third Degree. And we may therefore reasonably expect such a progression to be reflected in the Tracing Boards. In order that we may rightly understand the connection of our whole system, and the relative dependency of its several parts, we must grasp the sequence of ideas which link together the symbolic teaching in those Degrees. In fact, the Degrees may be regarded as three concentric circles—corresponding to three correlated spheres of Masonic speculation; the centre common to all three circles being a Knowledge of God, that being the sublime centre towards which we constantly press inwards from the outer circle of the E.A., whilst the three consecutive aspects of this Knowledge correspond to the peculiar titles T.G.A.O.T.U., T.G.G.O.T.U., and T.M.H., associated severally with each Degree.

I have already dealt with this part of my subject in a Paper read before the Lodge two years ago,* in which I endeavoured to show that after surveying (in the First Degree) the Constructive Force or Power pervading

* Published in Transactions for 1909-10, p. 58 *et seq.*

and constraining all material phenomena, we pass (in the Second Degree) to an inner circle wherein we analyse those rational laws—i.e., Gravitation, the Conservation of Energy, etc.—under which the universe is governed and regulated. The Sacred Symbol there discovered is an emblem of the Divine Purpose manifested in the prescience and predestination of its every detail by the Grand Geometrician, which compels us to confess—

“That nothing walks with aimless feet ;
That not one life shall be destroyed
Or cast as rubbish to the void,
When God hath made the pile complete.” *

Fortified with the knowledge thus obtained, we are conducted (in the Third Degree) to the innermost circle of all—the realm of human self-consciousness and determinism. To the consistent M.M. annihilation has become an untenable prospect, for human personality and human responsibility have been already found inalienable tenets of our Craft. Haeckel’s hypothesis †—that the development of consciousness in any organism, its sense of right and wrong, and its control over its own actions, are merely functions of its brain-substance—now becomes equally untenable. For just as the mental world is superior to the material world, so does the moral world surpass both; and having been Masonically taught that everything has been caused to exist, and exists for a cosmical purpose, he (the M.M.) is finally assured that that purpose is a moral one. The principles of right and wrong cannot be based on human custom or mere social utility, but are inherent in the Purpose of T.M.H. Thus (as we are elsewhere told) our mysteries mark

* Tennyson : “In Memoriam,” liv.

† Haeckel —*das Welt-Räthsel* (English transl.) p. 6.

in a peculiar manner the moral relation we bear to the Almighty -- as creatures offending against His Will [גב ויררה] yet the adopted children of His Mercy [חסד]; a reflection with which we may appropriately close this part of our subject to-night.

II.

Having now briefly surveyed the history of our Third T.B. as explanatory of its present imperfect symbolism, and reviewed those sublime ideas concerning God which progressively link the three T.Bs. into one whole system, let us proceed to consider the esoteric teaching of the Third T.B. itself. In doing so we may at once discern a profound significance in the arrangement of its component details, as well as in the symbolism of each detail individually.

We are told that the peculiar objects of consideration in this Degree are two, by investigating which we are to prepare ourselves Masonically for "the closing hour of our existence" *here*. The foregoing quotation is one to be used with much caution, or it becomes a solecism. True, the objects of our research are the problems of Existence; but clearly Death is not the *conclusion* of Life. In fact the cardinal doctrine of the Third Degree is that "*Mors est janua Vitæ.*" Let us listen to the voice of Nature (confirming that of Revelation) assuring us that "in this perishable frame resides a vital

and immortal principle." Death is accordingly regarded as a mysterious Veil, a veil which (we are told) the eye of human reason can penetrate only when assisted by the Light from above. This solitary *Light in the East* is the V. of the S.L., for it is only by the information therein contained that the veil of Death is partly lifted, and a glimpse disclosed of Life extending behind and beyond it, in that Divine Presence which to our ancient brethren was typified by the Shekinah within the *Sanctum sanctorum*. This is the thought which readily will explain the central feature of the T.B. before us.

This innermost shrine of King Solomon's Temple was a square apartment, measuring twenty cubits in length, twenty cubits in breadth, and twenty cubits in the height thereof. It was constructed of cedar-wood from Mount Lebanon, richly carved with palm-trees, open flowers and cherubim (I. Kings vi. 29), and overlaid throughout with pure gold. Within this "oracle" were deposited five sacred and historic treasures of the Hebrew nation, viz., the Ark of the Covenant, the Golden Censer, the Golden Pot that had manna, Aaron's Rod that budded, and the Tablets of stone containing the ten commandments (Heb. ix. 4). Of these treasures the most important was the sacred Ark, a chest of acacia-wood symbolizing the throne of God, and bearing upon it two golden cherubim—as if attending on their Divine Sovereign, their outstretched wings indicating the promptitude and activity of their service, whilst their eyes—fixed ever on the Mercy-seat before them—suggest their admiration and reverence for those transcendent mysteries of Life and Love within the Ineffable יהוה .

Between these cherubic figures* shone the dazzling **שְׁכִינָה** † “Glory of the Lord,” the Self-revealed Presence of JEHOVAH, which was the peculiar mark of His favour and protection to the Chosen People.

In front of the Veil on the T.B. are represented the Ornaments of the M.Ms Lodge—the P.,D. and S.P. This P. (which must be entirely distinguished from the Great P. or E. to K.S.T.) was the entrance to the *Sanctum sanctorum*. The D. inscribed with the sacred motto—**קדש ליהוה**—is said to be the W. giving light to this P. from the *Sanctum sanctorum*. The S.P. was for the High Priest etc. Now the oft-disputed question, whether as a matter of historic accuracy King Solomon's Temple possessed such a P.,D. and S.P., is one which may be dismissed as irrelevant. Freemasonry is a system veiled in allegory, and whether the allegory is or is not fully supported by facts, is a comparatively unimportant detail. The essential factor is the philosophic and moral teaching illustrated by the P.,D. and S.P., and that factor is one of profound significance. For these Ornaments obviously represent our own position in regard to Death and Life, and teach the manner in which during this present existence the Freemason should in all his pursuits have Eternity in view.

Our learned Brother Oliver has said “From this P. we learn to open the p. of our hearts to a true belief in the doctrines contained in that holy Book which lies open on the pedestal of our Lodges, and thereby to best prepare ourselves to enter into the Most

* *Vide* armorial bearings of Grand Lodge of England.

† Sometimes spelt *Jachinai*.

Holy place (in heaven). The D. conveys a hope that the obscurity of our minds may be chased away by the Light shining into them from the Divine source of all wisdom and goodness. Whilst the S.P. teaches us that our minds and hearts should be so squared by the Divine hewings as to avoid the stumbling-blocks of vain janglings and deceit.”*

In attempting to-night to probe somewhat deeper into this moral teaching, I think we all feel instinctively that the nature of “LIFE—Here and Hereafter” is a subject on which Masonry surely has (or may fairly be expected to have) a word to say. It was a subject of deep research among our ancient brethren, and must be one of profound regard to us all. Our present human life is the Porch; its characteristics illumined by the First Great Light of our Craft—streaming through the D. and falling upon the chequered Pavement of Good and Evil—which Porch we can traverse only once, aided by our other two Great Lights.

I have said that we traverse this Life but *once* only, for, although Metempsychosis was undoubtedly an accepted doctrine in the Pythagorean and other ancient Mysteries, I believe it to be a doctrine inconsistent with true Speculative Masonry. It is a theory which, inasmuch as it furnishes a plausible explanation of all the apparent anomalies in the distribution of happiness and sorrow, frequently fascinated and influenced the minds of those alchemists and Kabbalists who (in mediæval times) preserved our philosophy; and therefore many modern Masonic students are inclined to view it with favour. But Metempsychosis (or “Transmigration”) is the hypothesis that every human soul passes at death from

* Oliver ; Freemasons' Treasury (1863), p. 313.

one body into another, thereby constituting an interminable cycle of successive births and deaths, within the present existent physical environment. Thus, whilst personality is transient, materialism is tacitly assumed to be everlasting. Originating in ancient India, the theory passed to the "Renaissant Egyptians"* and (according to Herodotus) from them to the Greeks,† though it never secured among these latter peoples a sufficiently wide acceptance to seriously modify existent belief in the soul's immortality (in a spirit-world), which belief had come down from prehistoric times. Plato, the greatest exponent of Metempsychosis, represents the spirits of the dead as being conducted into the presence of the Fates, there to have their destiny determined according to their merits; then, after drinking of the waters of *Λήθη* (whereby they forgot all that concerned their previous lives), they were carried away to new births, this way and that—like shooting-stars—their new environment, capacities and opportunities for attaining more (or less) comfort and happiness, being dependent on their merits or demerits in the last previous incarnation.‡

In contrast with that theory of Transmigration is the still older belief in the survival of personal identity and consciousness, though only in a permanently disembodied state. Here an immortality of the soul was presumed, but merely as of a shadowy ghost—either haunting its former terrestrial surroundings, or else passing irretrievably into a joyless and hopeless *Sheol* (*שְׁאוֹל*) or "Underworld," *i.e.*, "a land of darkness and of the

* Brugsch, *History of Egypt*, Vol. II., p. 283 (1st ed.).

† Herodotus, Bk. II., 123.

‡ Plato, *Repub.*, x. "Story of Er."

shadow of death, without any order, and where the light is as darkness." (Job x., 22).

But, brethren, our T.B. confirms neither of these fallacies. As we gaze beyond the parted veil of Death it is to behold not an interminable arcade of pillared porches, nor yet a grim grey crystal cavern peopled with misty phantoms flitting through perpetual twilight. Nay! The Ark and Cherubim, bathed in the Glory of the Lord, symbolize a far sublimer ideal of Life as the centre from which the M.M. cannot err. I will not appeal to sentiment however, for Science and Reason confirm the Light of Revelation, and unite in assuring us that progressive development as well as continuity of existence await every true and faithful Brother.

Let us reflect on that most interesting of all human studies—the knowledge of *ourselves*. We know that Man's body is an integral part of this material universe, a collocation of carbon, hydrogen, and other physical elements. But the "self" of Man is not his body, and it is the "self" which differentiates him from all other animate organisms. The "self" is not only alive, but is able to learn from the past and to strive towards the future, not merely evincing preference and aversion, but able to select (the morally) Good and to reject Evil. No other terrestrial creature can attain to such an adequate perception of its own identity as this, or can effectually change and control external matter and energy in order to accomplish certain preconceived purposes. No other organism can share—as in fact Man shares (to a considerable degree)—in God's management of the world.*

* Prof. Oliver Lodge, *Life and Matter*, p. 89.

Let us go a step farther. Science has helped us to realize that, for everything the "self" thinks and does, a body is absolutely necessary. Such is the interaction between the spirit and the body, that we cannot really conceive the nature of a spirit apart from those bodily senses through which the spirit manifests its consciousness and power. And, even though our real personality may be very unlike what to our present consciousness it appears to be, it is inconceivable that any further progress of the "self" can be effected (in the scale of existence) without a body of some kind; and thus the evidence of Science (if only circumstantial) corroborates the testimony of Revelation, that the Life typified by the *Sanctum sanctorum* is a Life of spirit and body. And, as we bear in mind the story of the exhumation of the body of H.A.B., it becomes impossible to escape from the conviction that our philosophy concerning the Life Hereafter must be associated with a "resurrection of the body," as the doctrine of the Third Degree.

But this "raising" implies not a mere resuscitation of the actual material particles which constituted the body at the moment of dissolution, nor yet a return to the various limitations and hindrances incidental to mortality. The grain of corn sown undergoes a chemical disintegration, whilst, from the life latent in it, there germinates a new plant which in due course becomes a reproduction of the original. But the continuity of identity, in the seed sown and the grain which springs from it, involves no continuity of its constituent particles. "So also is the resurrection of the dead." There must be a preservation of personal identity (involving the entire "self," i.e., spirit and body), but changed and adapted to a very different environment.

For the fundamental characteristic of this "new heaven and new earth" will be *changelessness*. At present, the all-pervading law in the universe is what is called Periodic Change. Growth and decay, evolution and devolution, inseparably prevail—always and everywhere. And although the transmission of life by reproduction might seem to point to a succession of living organisms extending *ad infinitum*, such an idea is negated by the fact that not only is it possible that Matter itself must ultimately cease to exist as Matter, but even the Energy of the universe (though undiminished in amount) will become no longer capable of further transformations; and without such transformations no living organism under present conditions could continue to exist. True indeed are the words—"they all shall wax old, and as a vesture shalt Thou change them and they shall be changed; but Thou art *The Same* [אֵתֶרָה הוּיָא] i.e., the *Changeless One*."* And this "change" must be the supercession of Refluctation by Progression. In the *Sanctum sanctorum* of Eternity can be no more Death but only Life—Eternal Life.

May we not then fairly claim that these reflections, according as they are comprehended, will enable us to contemplate the emblems of mortality with equanimity, and afford to the M.M. "a reward which amply compensates for all his attention and assiduity" ? †

* Psalm cii. 27.

† Introd. to Third Lecture.

III.

It would, however, be foolish to ignore the fact that the emblems of mortality have also an allusion to the traditional death of our ancient G.M.H.A.B., who lost his life in consequence of his unshaken fidelity to the sacred trust reposed in him. It has been asserted (and may probably be true) that the secrets which he refused to divulge were partly of an *operative* nature. Undoubtedly, the length of certain rods* in the proportions of 3 : 4 : 5, necessary in marking out the site (for ensuring truly rectangular corners) for the intended structure; the knowledge that the angle in a semicircle is invariably an angle of 90° (so that, with the compasses, that angle could be constructed in any required position without the possibility of error); above all, the principle of the catenarian arch and the properties of the keystone; these were secrets which, from time immemorial, had been jealously guarded by the operative M.M. But there is no sufficient reason to disbelieve our tradition that these (and other operative secrets) were combined and communicated together with certain philosophical ideas concerning Death and Immortality.

Whatever those secrets may have been, the fact upon which stress is laid in our mysteries is the unshaken fidelity of our G.M.H.A.B. in defending them. The details of our traditional history concerning his death are familiar to us, and need not be recapitulated. The W.T.s with which the base deed was accomplished (the P.L. and H.M.) are represented on the T.B., together

* They are Sceptres in the Holy R.A.

with the initials of our G.M.'s name in the secret Masonic cypher,* and the date of the event referred to.

(Here followed an oral demonstration which, for obvious reasons, cannot be printed.)

.

In addition to these secret marks peculiar to our Craft, we find a triad of Hebrew letters, all denoting one and the same numeral. This ternary repetition of certain symbols is itself a significant detail, constantly used in our doctrines, our ceremonies and our moral teaching. In our three Degrees, three Principal Officers, three Ls., three Ps., three Movable and three Immovable Js., three Working Ts. in each Degree, we are to see an emblem of all *work* in the Lodge fitly directed to the three Grand Principles of the Order.

When added together these three numerals obviously allude to the trusty F.C.s who were ordered to make a diligent search for the P. of our M. "to ascertain, etc." They departed in different directions to fulfil their work, and, after many days spent in fruitless endeavour, one band returned without having made any discovery of importance. The second band were, however, more fortunate—inasmuch as they found that which is familiar to every M.M.; and to mark the spot, stuck a sprig of acacia (*acacia seyal*)† at the h.o.t.g, whilst they hastened back to Jerusalem, to impart the intelligence to their Master. In the meantime, five of their companions

* Bro. Hughan has suggested that the use of two *words*, distinct though of similar import, belonging to the ss. in this Degree, is to be explained as one of the differences between the "Atholl" and the "Regular" Lodges, which was adjusted at the Union in 1813 by sanctioning both the words.—(*Origin of Eng. Rite*, p. 88, in ed. 1909).

† "The loved and lone acacia-tree," Moore : *Lalla Rookh*.

(whose names are traditionally given as Zabud,* Stolkin, Benaiah, Ahinadab and Gomar) had made another discovery relative to the matter, in a cavern near Joppa, as the result of which they brought back certain prisoners with them, to be judicially dealt with by S.K.I. An important variant of this tradition† represents Zabud as impetuously exceeding his instructions by rushing forward before his companions could intervene and rashly slaying Akhiroh [אֲחִירוֹהַ] whilst asleep, an indiscretion which was subsequently pardoned by S.K.I. in response to their urgent intercession.

When we regard these aforesaid Hebrew numerals separately and individually, they are seen to symbolise the ss. of the Degree, and the corresponding Pts. of Fellowship, together with a secret now associated with the R.A.

(Another oral explanation here.)

.

Finally: above the Emblems of Mortality are represented the W.T.s of the M.M., in order to remind us that, together with the contemplation of our inevitable destiny, we must combine a constant care to perform our allotted tasks while it is yet day.

The first W.T. points out that straight and undeviating line of Duty laid down for our pursuit in the V. of T.S.L.; for, as we have already seen, Duty and Responsibility are inseparable from the "Mors janua Vitæ." Similarly, the P. teaches us that our words and actions are recorded by the Almighty Architect; whilst the C.s remind us of

* 1 Kings, iv., 4-5.

† Referred to in several degrees of the A. and A. Rite.

His unerring justice; Who, having defined for our guidance the limits of Good and Evil, will reward or punish (in the Hereafter) as we have obeyed or disregarded His commands. Thus, the W.T.s of the M.M. teach us to ever bear in mind, and act according to, the laws of our Creator, that, when we are summoned hence from this sublunary abode, we may ascend to the true Sanctum Sanctorum—where T.G.A.O.T.U. lives and reigns for ever.

S.M.I.B.

Bro. J. T. THORP proposed a Hearty Vote of Thanks to Bro. COVEY CRUMP for his Paper; this was seconded by Bro. F. W. BILLSON, supported by Bro. A. LOLE and the W.M. The latter expressed a hope that Bro. COVEY CRUMP would allow it to be published in the Transactions. The Vote was unanimous and in responding, the lecturer thanked the Brethren present for their patient attention, stating that he would be pleased to grant the W.M.'s request.

It was subsequently resolved that Bro. Rev. W. W. COVEY CRUMP be requested to accept Honorary Membership of this Lodge, for by so doing he would honour it. Bro. COVEY CRUMP expressed great pleasure in acceding to the request.

Bro. J. T. THORP suggested, and it was resolved, that the Lodge re-publish as a memorial to the late Bro. HUGHAN, his "Old Charges of British Freemasons."

Apologies for non-attendance were received from Bros. J. A. SHERREN (Weymouth); T. J. RALLING (Colchester); G. W. BAIN (Sunderland); H. G. BURROWS (London); R. H. BAXTER (Rochdale); R. C. LEVERSEDGE (Bath); C. S. BURDON (London); W. LONNON (Portsmouth); W. H. QUARRELL (London); C. F. OLIVER, J.W.; W. T. TOPOTT; Rev. C. T. MOORE; W. A. LEA, P.M.

Hearty Good Wishes were tendered by the Visiting Brethren, and the Lodge was closed.

“‘Not so,’ he said, ‘but he was mortally wounded; I found him on the battle-field after he had been plundered, and spoke to him. He gave me the sign and token of a brother of our craft, and being a Freemason myself, I took him from that moment under my charge. I was sent to Bayonne with our wounded and many of your prisoners, and poor Day was my especial care. I got him so far, and made his wasting life as quiet to him as possible. He wanted for many things that I had not in my power to provide. I got him cash for a bill on England, which I may say was duly honoured, but he did not survive over a couple of weeks or so, and he was buried with Masonic honours.’

“This was the *finale* of a good soldier. He fell into the kind hands of a brother Mason, and was not left, as we thought, on the field amongst the slain to be devoured by the vultures. I resolved, after hearing this little chivalric story, to become a Freemason if I got safe home, and I carried out my resolution.”

General Bell, as befitted a Masonic Brother, was a most humane officer, with ideas on the kind treatment of those placed under him, far in advance of his time. During his earlier term of service corporal punishment was rife in the British army. He himself says:—“Corporal punishment went on all the year round. Men were flogged for small offences, and for graver crimes flogged to death. A thousand lashes were often awarded by court-martial. We certainly had some bad characters, but such punishments were inhuman, and I resolved in my own mind, if I ever had the chance of commanding a Regiment, I would act upon another principle. The time *did* come, and I *did* command a

gallant corps for eleven years and abolished the lash. Kindness is the key to open the human heart, and with that key I reformed the worst characters."

W. THOMAS,

398 Halifax, N.S.

The 3.4.5 Triangle in the Great Pyramid.*

By Bro. ARTHUR BOWES, A.M.I.C.E.

In the Transactions of the Lodge of Research for the year 1910-11, I described, under the heading "Masonic Secrets of the Pyramids," certain proportions of those structures which appeared to depend for their origin upon the use of the 3.4.5 triangle and the Vesica Piscis. In that contribution, so far as the Great Pyramid was concerned, most of the proportions dealt with were shown to agree fairly well with figures based on the Vesica Piscis, or, ultimately, on the equilateral triangle, and little or no trace was found of any influence of the 3.4.5 triangle in the Great Pyramid itself, as distinct from the neighbouring pyramids. Since then I have found a very interesting and, in my opinion, convincing proof that the 3.4.5 triangle was used in the design of the King's Chamber of the Great Pyramid to determine the proportions of that apartment. As to what might be the object of embodying these particular proportions in the building we can only surmise. Perhaps it was a question of utility and convenience; perhaps it was with the intention of preserving in a secret and hidden manner the true ratios of a triangle whose valuable properties may have been restricted to a specially instructed order.

* *Vide* Plate IV.

The measurements of the King's Chamber are known to be,—length, 34 feet; width, 17 feet; height, 19 feet. The floor is a rectangle twice as long as it is broad, and, consequently, as I pointed out in the previous contribution, was one of the many figures which could have been set out by means of the 3.4.5 triangle, though this would have been rather a round-about method of proceeding. Also, as before referred to, the end wall, 19 feet by 17 feet, agreed fairly well with the proportions of 19.6 feet by 17 feet which would result from the use of the hexagon or two Vesica diamonds. I now submit a much more accurate agreement with another method. The illustration herewith shows the proposed theory diagrammatically.

The length of the line **a** in the diagram, *i.e.*, the **3** side of the triangle, will be $\sqrt{19^2+17^2}=25.5$. The length of line **b**, *i.e.*, the **4** side of the triangle, is known to be 34. To find the length of the solid diagonal of the chamber, *i.e.*, of the **5** side of the triangle, we must first find the diagonal of the floor, $=\sqrt{34^2+17^2}=38$, and taking this in conjunction with the height of the chamber, 19 feet, we find the solid diagonal to be $\sqrt{38^2+19^2}=42.48$. This, as we have said, represents the 5 side of our assumed 3.4.5 triangle. The three sides of the shaded triangle in the diagram, just fitting into the chamber, are thus 25.5, 34 and 42.48. Reducing these to the lowest possible figures by dividing by 8.5 they work out to the ratio 3.4.5 with an accuracy which is much closer than can have been attained in taking the actual measurements of the chamber.

The One Hundred=and=Third Meeting

of the Lodge was held at the Freemasons' Hall, Leicester, on Monday, March 25th, 1912. The Worshipful Master, Bro. GEO. BONNER, presided. A large number of Members and Visitors were present.

The following six Brethren were declared duly elected Members of the Correspondence Circle of the Lodge, viz. :—

- 757. Bro. Rev. J. A. DRYSDALE, S.W. 3330 Rangoon ;
Chap. D.G.L. Burma.
- 758. Bro. W. H. WENDON, P.M. 3020 and 3078 ;
W.M. 3090, S.W. 869 London.
- 759. Bro. JOHN TOM COOPER, 523 Leicester.
- 760. Bro. W. H. STAYNES, P.M. ; P.M. 2081 Leicester ;
P.P.J.G.W.
- 761. Bro. W. GREENAWAY, 2904 Maymyo, Burma.
- 762. Bro. Rev. HAROLD AUGUSTUS HARRIS, J.W.
1663 Eye ; Prov. G. Chap. Suffolk.

The following Paper was read :—

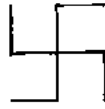

Operative Free Masons and Operative Free Masonry.

By THOMAS CARR, M.D., P.M.,
Member of the Guild of Operative Free Masons.

- (1). Existing Lodges of Operative Free Masons and the Worshipful Society of Free Masons, Rough Masons, Wallers, Slaters, Paviers, Plaisterers and Bricklayers.
- (2). The Third and Fourth Degrees of Operative Free Masons and some Masons' Marks.
- (3). The Genuine Secrets of the Master Mason. The Rods and "Squares" of the Three Masters. The Square—the Oblongs—the Octagon.
- (4). The P.M. Jewel and its meaning.
- (5). The Three Mountains of the Operative System.
- (6). The Swastika and the Pole Star Cult. Its ancient History. Its Turanian origin.
- (7). The Operative origin of Speculative Free Masonry.

I.—EXISTING LODGES OF OPERATIVE FREE MASONS.

Most Speculative Free Masons are aware of the fact that a Guild of Operative Free Masons still exists, and it is the Ritual and practice of some of these Operative Free Masons that we are to consider to-day.

I am myself a member and officer of two of their Lodges, both Lodges belonging to the York Division of the Worshipful Society of Free Masons, Rough Masons, Wallers, Slaters, Paviers, Plaisterers and Bricklayers.

At first sight this somewhat comprehensive title is a little difficult to understand. But it must be remembered, that in many towns and districts there would not be enough Free Masons to form an independent Society, so that it was customary for them to associate with, and form a Society of themselves and other kindred craftsmen; although their own particular art or craft was reserved as to its training and practice to their own apprentices and craftsmen.

This association of other trades with Masons was not at all an uncommon state of affairs in the 17th century.

In Kendal, in 1667, the 12th Trade Company comprised Free Masons, Rough Masons, Wallers, Plaisterers, Slaters and Carpenters.

In Oxford, in 1604, a company was incorporated entitled "The Company of Free Masons, Carpenters, Joiners and Slaters of the City of Oxford."

In Gateshead, in 1671, incorporation was granted to "The Company of Free Masons, Carvers, Stone Cutters, Sculpturers, Brickmakers, Tilers, Bricklayers, Glaziers, Penterstainers, Founders, Neilers, Pewterers, Plumbers, Millwrights, Sadlers, Bridlers, Trunckmakers and Distillers."

In 1594 Bishop Hutton of Durham incorporated the "Rough Masons, Wallers and Slaters." In 1609 Bishop James confirmed their Bye Laws and Ordinances, in which they are designated "Rough Masons, Wallers, Slaters, Tylers and Plaisterers"; and on April 16th, 1638, Bishop Morton gave a new charter to "The Company

Societee and Fellowship of Free Masons, Rough Masons, Wallers, Slayters, Paviers, Plaisterers and Bricklayers," which is the same Society in name as that which exists now, although owing to strikes and to trades' unions in recent times, the other trades associate less with the Free Masons than formerly; the Society, however, still retains its old title.

The Operative Lodges to which I have the honour to belong are Nos. 91 and 110.

No. 91 was founded as a separate Lodge in 1761 and meets at Leicester, but still remains under York, whence it came.

No. 110 is the Mount Bardon Lodge, and meets at the Quarries at Bardon Hill, near Leicester, and that also belongs to the York Division because of its origin. There are three Speculative Masons who hold office in these Lodges, and twenty-one who are Corresponding Members, besides W. Bro. Stretton, who was apprenticed to the Society as a lad and has passed through every grade up to that of the VII^o.

The advantage that is mine, is that as Surgeon of these Lodges I have the right—even the duty—to be present at some of the ceremonies, and have a part to play in one of their annual dramas.

I am indebted to my friend, W. Bro. C. E. Stretton, Civil Engineer, of Leicester, P.Prov.G.S.W. of Leicestershire, and Past Third Grand Master (VII^o) in the Operative, York Division, for my introduction to office in both these Lodges.

My thanks are due to the Operative Lodge, Mount Bardon, for the information which is about to be submitted to you to-day, the Masters of which have done me the further honour of selecting me as their medium

of communicating some of their Ritual, their Marks, and their Technical Secrets to my Speculative Brethren.

The Operative Free Masons divide all who follow their art into two classes.—I. Arch or Round Masons—who do curved work and whose symbol is the compasses, and whose colour is Red. II. Square or Straight Masons—who do square work and whose symbol is the right angle or square, and whose colour is Blue.

Each class comprises seven degrees:—

- I. The Apprentice to the Craft of Free Mason.
- II. The Fellow of the Craft of Free Mason.
- III. The Super Fellow who has his Mark.
- IV. The Super Fellow who is an Erector.
- V. The Intendent and Super Intendent.
- VI. The Certified Master or Passed Master.
- VII. The Grand Master, First, Second and Third.

It is obvious that in one short paper it is not possible to tell you much of the Ritual, but some salient points that have special bearing on Speculative matters have been selected, which will, it is hoped, enlighten and interest you.

II. —THE THIRD AND FOURTH DEGREES OF OPERATIVE FREE MASONS AND SOME MASONS' MARKS.

After the Operative Apprentice has served his allotted time of seven years, he has to be released from his apprenticeship and made free of his bond. The neck-cord which he has worn during his apprenticeship is removed and his indentures are torn up.

He then has to submit a rough-dressed Ashlar Stone as a test of his skill in the craft, and he is then eligible to be made a Free Mason and passed to the Second Degree, that of the Fellow of the Craft of Free Mason. He is then, as a Fellow, taught to make his rough-dressed Ashlar Stone true and polished.

Then his perfect work has to be submitted for inspection and to be tried. If the work is satisfactory he is given a word, which means "perfect stone squarer" or "expert Mason."

With this additional or superior word he is given an additional sign, of which there is no trace in the Speculative Ritual. The sign is



Thus he represents all three of the tools of this Degree, namely, the Square, the Level and the Plumb-rule. He is now eligible to be advanced to the Degree of a Super Fellow, which is the Third Degree among Operatives.

This Degree corresponds very nearly to the Mark Man or the first part of the Speculative Mark Degree, and the candidate is not only told to produce "Fair work and Square," but he is also taught how to do it. In this Degree he has a Mark given to him, and is further taught the method of preparing stones for the builder, by fitting them and marking them, so that the actual erectors

should have no trouble in putting them together properly in their intended places.

After working in this Degree for one year the Super Fellow is eligible to be further advanced to the next Degree, which is the Fourth, and is known as that of a Super Fellow Erector. This means he is qualified and entitled to erect and put in position on the site the stones prepared in the 1st, 2nd and 3rd yards, and marked in the 3rd stone-yard.

The Super Fellow Erector ascertains from the marks the exact position in which each stone is intended to be placed.

It is in this, the Fourth Degree, that the Annual Ceremony of the Foundation of King Solomon's Temple takes place. The Hebrew influence is shown by the Mason having in this ceremony to remove his shoes and keep his head covered.

The Mason in this Degree has to be expert in all constructional marks.

When the stone first leaves the quarry it has the quarry mark upon it. Then when the apprentices in the First Degree yard work upon it, this quarry mark is removed, and the apprentices responsible for its rough dressing, who have removed the quarry mark in the course of their work, put their mark upon it. Then the Fellows will further prepare the stone and will put a bench mark upon it in some place where it will not be seen, or if that is inconvenient will mark it with paint. Then the Third Degree man or Super Fellow will put his own mark upon it, and also the constructional mark, so that the Erector may know where it goes and in what direction to place it. Among some of the more important marks of the Operatives are the following:—*

* *Vide* Plates V. to XI).

III.—THE GENUINE SECRETS OF A MASTER MASON (OPERATIVE).

I want next, briefly and very concisely, to describe some of the secrets restricted to the VII. Degree, or that of a Master Mason (Operative).

There are three Master Masons, and three only, in an Operative Lodge. Sometimes Apprentices working in the First Degree may have a Second or Third Degree Mason put over them to rule them *as* Master, and for the time being he is *their* Master; or a Fifth or Sixth Degree Mason may be put as Master over a Lodge working in the Second or Third Degree,—but the whole Lodge has three Master Masons to rule them, and three only. “Three to rule a Lodge.”

The First Master represents Solomon K.I., the Second H.K.T., and the Third H.A. We have an intimation of this arrangement in Grand Lodge and in Provincial Grand Lodge. There are many Operative secrets restricted to these Masters alone.

The 3.4.5 Rods.—Upon the right use and knowledge of these rods depended many jealously guarded and valuable trade secrets, still preserved by the Guilds.

That of the First Master was five inches,—feet or cubits make no difference; that of the Second Master was 4; that of the Third Master was 3; and the three Masters had to meet and agree to place the three rods together for them to be of any use.

Plutarch says that in Egypt the three rods were dedicated to Isis, Osiris and Horus, and each had a special colour, black, red and blue, and represented respectively the originating, the receptive and the product.

In the Operative Masons' Guild each rod also has a special dedication, but I cannot (being an Arch Mason) tell you what they are. My Royal Arch companions can, however, supply the omission.

Place three such rods together, and what do you get? A right angled triangle, of which the sides measure respectively 3, 4 and 5, and of which the contents measure 6. I find this fact, that is, that a triangle formed of three sides of 3, 4 and 5 gives you a right angle, is not only known to engineers and land surveyors to-day, but is constantly used by them when they want to set out a right angle accurately on the ground; and not only is it known to modern engineers, but Vitruvius, a Roman architect who lived shortly before the Christian era, in his celebrated treatise on Architecture, which was dedicated to Augustus Cæsar and published about 25 B.C., describes accurately how it is done, in Chapter II., Book IX. He says, "Pythagoras demonstrated the method of forming a right angle without the aid of the instruments of artificers: and that which they scarcely, even with great trouble, exactly obtain, may be performed by his rules with great facility. Let three rods be procured, one three feet, one four feet, and the other five feet long; and let them be so joined as to touch each other at their extremities; they will then form a triangle, one of whose angles will be a right angle."

He then goes on to show, to use the words of Euclid, who flourished some two centuries later than Pythagoras, that "the square which is described upon the side subtending the right angle, is equal to the squares described upon the sides which contain the right angle." To conclude in the words of Vitruvius, "when Pythagoras

discovered this property, convinced that the Muses had assisted him in the discovery, he evinced his gratitude to them by sacrifice."

But this is not all the secret of the 3.4.5 triangle. When you have once got this right angled triangle, you can erect a square building exactly and accurately of any given size, also an oblong building of 2 to 1 of any size, also an oblong building of 3 to 1 of any size.

The only data you need are the centre of the building and its size. In ancient days the size was measured from the centre of the building to its four corners.

In the case of a Square Building the centre was marked, two triangles were placed 90° angle to 90° angle, with their corresponding sides in a straight line, and then the required distance along these extended lines was measured off. This being done, the four corners,—each to subsequently have its corner-stone in position,—were determined. Thus you had *five points*, and when these were determined all else fell into due place.

In the case of an Oblong Building 2 x 1, the centre was similarly marked, two triangles were placed with the angles intermediate in size (53.8°) opposite one another with their corresponding sides in a continuous straight line, and then the required distance along these extended lines was measured off, and again you get your *five points*, and the rest all fell into due place.

In the case of an Oblong Building 3 x 1, the centre was similarly marked, two triangles were placed with the angles smallest in size (36.52°) opposite one another with their corresponding sides in a continuous straight line, and then the required distance along these extended lines was measured off, and again you get your *five points*, and the rest all fell into due place.

(The two ways in which the five points are demonstrated by Operative Free Masons were then illustrated.)

The Octagon is derived from the Double Square. But to lay out the Octagon when you cannot get to the centre is done by means of a Retractor. The geometrical books do not give a satisfactory way, but by dividing 360° by the number of angles required, you get the size of each angle, and can then construct any polygon, e.g. :—

$$\begin{array}{r} 8 \) \ 360 \ (\ 45 \\ \underline{32} \\ 40 \\ \underline{40} \\ \hline \end{array}$$

shows that 45° is the angle required for an octagon.

IV.—THE P.M. JEWEL AND ITS MEANING.

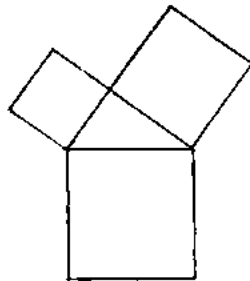

Euclid I. 47.—From what has just been placed before you, you will see why this is an appropriate emblem for a Mason who is or has been a Master Mason. It is because he has learned the use of the three rods which make the right angled triangle, which are represented in this figure, and which as far back as the time of

Pythagoras, some 2500 years ago, connoted the knowledge of the fact that the square of the side which subtends the right angle is equal to the sum of the squares on the two other sides.

The Operative Master Mason has this proposition explained to him, and it is further pointed out that the total area of a figure is 56. It is also pointed out that the proper way to make this figure is as now shown on p. 120. Usually you will find it represented the other way.

The Frontispiece to the 1723 Book of Constitutions, and also that of the 1738 edition, shows this problem represented the other way (with the 4 square on the left side), but Brother Euclid's letter to the Editor has this figure represented the proper way, as now shown.

The Operatives say that as H.K.T. was on Solomon's right hand and he had the 4 rod, the only proper way is to have the 4 square on the right hand. The proper way to regard our P.M. Badge is as though one were looking at it oneself from the inner side.

Each Master has a Square or Right Angle such as now shown. You will see these each have the 3 and 4 side, while the 5 side is between the ends.

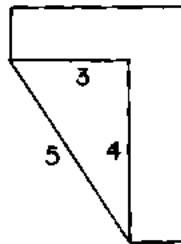

There is also another square on the Vol. of the S. L., making a fourth. Putting these four Squares together, thus—

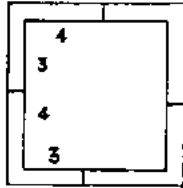

you get a Master's Square, and putting them together thus—

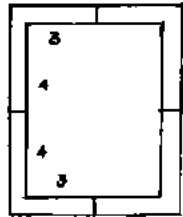

you get a Master's Oblong. It is this oblong which forms the frame of 47 Euclid I. in our Past Master's Jewel.

It is of great interest to find Vitruvius quoting Pythagoras as the finder of this property of the three rods, which forms the basis of I. Euclid 47, as not only does modern Speculative Masonry, but some of the old Operative Charges, including the Matthew Cooke, dating back to the early 15th Century, claim Pythagoras as one of the founders of Masonry.

The "Levels" which Past Masters wear on their aprons are considered by Operative Free Masons to be Footing Stones, which were used for the foundations of all important buildings.

Another use of the Triangle was to form the Master's Diamond; which we have in our Tessellated Border and again in our Royal Arch Sash and Apron.

V.—THE THREE MOUNTAINS OF THE OPERATIVE SYSTEM.

The Operatives have one great Annual Assembly which every Mason is bound to attend if possible, as pointed out in Article 23 of the Charge to Fellows of the Craft of Free Mason, given to every Mason when passed as a Fellow.

They traditionally base this assembly on that made by King Solomon, and set forth I. Kings viii. 1 and 2. In addition to this great annual assembly, which in the York Division is usually held on October 30th, they also have three great annual ceremonies.

(1). The commemoration of the Foundation of King Solomon's Temple, in April.

(2). The commemoration of the Death of Hiram Abiff, on October 2nd.

(3). The commemoration of the Dedication of the Temple, on October 30th.

The tradition is, that Free Masons have held these annual commemorations ever since the building of King Solomon's Temple, and that these ceremonies are based on their own traditions, and are only illustrated by the Bible narrative. All that is certain to an observer is, that there is much in their ceremonies which is beyond the Bible narrative, although quite harmonious with it. In all these annual ceremonies the VII° and VI° Masons open separately and then conjointly form the Sanhedrim.

At the Foundation Ceremony, which takes place in April or May, the Sanhedrim is opened very early in the morning, as the sun should be saluted at its rising.

When this is properly done the Arch Masons salute when half his disc is above the horizon, and the Square Masons when the whole disc is risen.

But I am now more especially concerned with one of the references in the Sanhedrim.

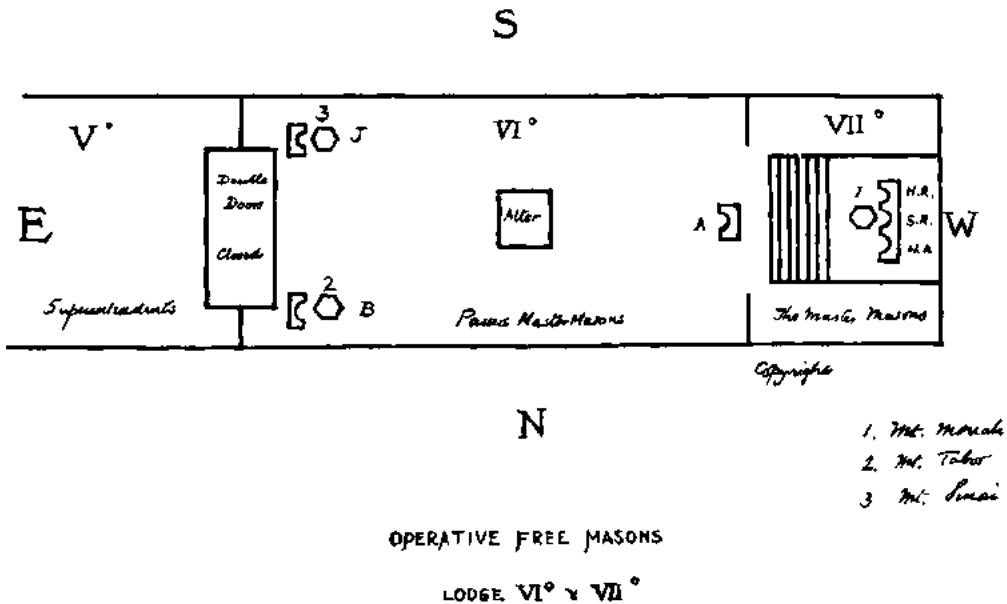

The Three Master Masons are seated in the W. The occupant of the Central Chair represents the Royal Solomon, on his right sits Hiram, King of Tyre, and on his left Hiram Abiff. They are regarded as being on Mount Moriah.

In the Chair in the S.E. and facing them is the Chaplain representing Jachin, and he is regarded as being on Mount Sinai.

The occupant of the Chair on the N.E., who is also facing W., represents Boaz and is regarded as being on Mount Tabor.

The Deputy Master, who has a chair at the feet of the Three Masters, represents Adoniram. The Deputy Master hands a blue cord up to King Solomon, who fixes it to the pillar in front of him, which is hexagonal in shape, and commands that it be carried to Boaz, who fixes it to the hexagonal pillar in front of him, then it is carried from Boaz to Jachin, who fixes it to the hexagonal pillar in front of him, whence it is carried back to Solomon. The angles so made by the cord are separately taken and of course together must make 180°. This blue cord is regarded as the great line of communication between the Three Mountains or High Places.

The Operatives further explain that as the First Master represents Solomon the King, and that as Jachin was High Priest at the time of the Dedication, so he represents the Church, and Boaz, the founder of the Royal House of David, represents the State. So King and Church and State are represented and united by the symbolical blue cord.

The anachronism of having Solomon and his ancestor Boaz represented as being present on the same occasion, is quaint and interesting.

But I think this little ceremony of the Sanhedrim shows that it was the source whence the opening of Grand Lodge and of Provincial Grand Lodge was derived.

The Ceremony of the Speculatives seems to be an altered and mutilated one of the ceremony we have just considered.

The G.P. says the position of the J.G.W. is in the South,—but the J.G.W. says his position is on Mt. Tabor, which is N.

The J.G.W. says the S.G.W. is in the W.,—but J. says his position is on Sinai, which is South.

Added to which the Speculatives only mention two mountains, whereas three seems a much more likely number and does not leave out Mount Moriah, the most sacred of all.

The Operatives further explain that the Candles on the three pillars represent the fires which were anciently kept burning on these three mountains.

VI.—THE SWASTIKA AND THE POLE STAR CULT.

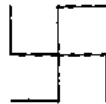

The Swastika is probably the most ancient and the most widely distributed symbol that has ever existed. It has been found on Chaldean bricks; among the ruins of the earlier cities of Troy (third, fourth and fifth); in Egypt (notably XIIth Dynasty); on the vases and pottery of ancient Cyprus; on prehistoric antiquities of Greece and Mycenæ: on the vases and pottery of the ancient Etruscans; on Hittite remains; on rock walls of Buddhist cave temples in India; in ancient China and Japan; in prehistoric American Indian mounds; on prehistoric remains in Central America and South

America. In later or historic times it has been found on Roman altars; on Runic monuments in Great Britain; on Gothic and Scandinavian weapons and ornaments; in the Coptic Church of the Xth Century; on English brasses of the XIIIth and XIVth Centuries, as well as in many other parts of Europe. It is still used in India, Thibet, China, Korea and Japan as a sign of long life, good wishes and good fortune; and also by the Lapps and Finns and some of the present North American Indians.

For many years this symbol has attracted my attention, and although one cannot here spare time to go into the reasons and arguments for the conclusions to which I have come respecting it, they may be briefly summarised:—

(1). It was spread throughout the world before the dispersion of the Aryan Race—in the Bronze Age—and by the Turanian or Yellow Race, who were the ancestors of the Chinese, Japanese, the American Indians, Etruscans, Hittites and other Mongolian and Altaic peoples.

(2). It was a symbol of Axial Rotation and referred to the Pole Star and the Rotation of the Great Bear round it.

(3). It symbolised the Great Ruler of the Universe who alone was stationary and stable at the North Star, while all the rest of the universe revolved around Him.

The course of reasoning by which I arrived at these conclusions is set forth in "The Swastika," published in the U.S.A. last year, and of which an English and improved edition is now in preparation.

Please bear in mind that no other writer has ever published views anything like these I hold, and then you can better estimate with what feeling I learned

the esoteric teaching with regard to the Swastika, that is part of the Secret Knowledge of the Operative Master Masons VII°.

When the Three Master Masons of an Operative Lodge meet together each wears a "Square" such as has been already described. There is also a fourth "Square" on the V. of the S.L.

When they open a VII° Lodge these four squares are placed together so as to form a Swastika, and you will observe a true and well-formed Swastika consists of four squares, or of four 3.4.5 triangles.

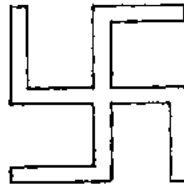

El Shaddai the Most High is first saluted, and then the Pole Star.

When the Operative Free Mason is made a VII° or Master Mason, the Swastika and its symbolism is explained to him, and it is revealed to him that the mighty God, the hidden sun in the centre, round which the celestial world is arranged, is not the Solar Orb, but the Pole Star. The new Third Master Mason has to go down below into the centre chamber under the Lodge floor, he is told to raise his eyes to heaven, and look up the plumb line which depends into the chamber in which he is placed. At the top of the plumb-line he sees "the Star of Heaven," the Pole Star, the "I am," the "G" in the roof, and he is ordered to worship.

He is further told that the plumb line comes down from the Pole Star, that the Swastika is its symbol and represents El Shaddai or the Most High Himself.

The Operative Free Masons tell me, that in the old days they had a blue lamp always burning at the G. in the roof for Square Masons; and a red lamp always burning for Arch Masons. The lights are still used, but are not now always kept burning.

The Swastika as a symbol is older than the Sanscrit language or the Buddhist religion; it originally meant axial rotation with reference to the Polar Star, and was the Symbol of God Himself.

I do not think we need wonder at the ancient world being so impressed with the stability of the Pole Star, and the stately procession of the Ursa Major around it. They saw the sun journeying across the heavens every day in a slightly different track, then standing still, as it were, at the solstice, and then returning on its way back again. They saw the moon changing not only its orbit, but in its size and shape and time of appearance.

And they saw the whole canopy of the stars wheeling round the heavens in a stately procession.

The Pole Star alone appeared stable—the Pole Star alone was fixed and at rest.

No wonder they connected it as the very footstool of the Most High, or El Shaddai Himself.

From this you will see that the “Blazing Star” is the emblem of the Pole Star, and not of the Sun as our Tracing Board has it.

Holding such views as to the ancient and original meaning of the Swastika, you can imagine, Brethren, what my feelings were, when I found these views (which are not generally accepted or even known) were more

than confirmed by the esoteric teaching of the VII^o Master Masons of to-day.

Do you wonder that I am an enthusiastic supporter of the claim of these Operative Free Masons, that their traditions and teaching are most ancient and of undoubted authenticity?

I go further, and believe that in much of the geometrical and esoteric knowledge of these Operative Free Masons, we have traditions that go back to the dawn of building, and to the Turanian race of builders who were erecting those cyclopean works at Baalbek, the Pyramids in Egypt, and buildings in China and in Akkadia and in America long before our Aryan ancestors had commenced their prehistoric dispersion.

Modified these traditions have been by their passage through the hands of the Roman Collegia, the Comacine Masters and the Gothic Fraternities,—deeply and mysteriously impressed by Hebrew teaching and practice—but in root and essence still showing signs of their primitive Turanian origin. Brethren! you need not be startled by such a far-fetched origin for our mysteries. The Arts and Letters of this modern civilisation of ours are likewise and admittedly based on the Arts and Letters of these same Turanian people, only we are so accustomed to them, that we are apt to forget the people of a different and long-perished civilisation to whom we are indebted for them.

VII.—THE OPERATIVE ORIGIN OF SPECULATIVE MASONRY.

There is no doubt that in former days the fanciful histories of Free Masonry as given by Dr. Anderson in his "Constitutions," and as described by Oliver in his

writings, did a good deal to alienate the interest of serious historians from Masonic history generally, and prevented them from investigating what amount of truth there was in the old traditions, which had become lost or hidden in the accumulated and fantastic imaginings of writers of that class.

W. Bro. Gould did a good work when he wrote his classic *History of Freemasonry*, in 3 vols. It is somewhat heavy reading I admit, but it is the work of a legal scholar, and no student of Masonic history can afford to be ignorant of its contents. The careful perusal of that great work leaves a clear impression on one's mind, that Speculative Free Masonry is derived from Operative Free Masonry. So distinctly is this so, that it has been a surprise to me to find, that there are a few writers who still hold that Speculative Masonry did not spring from Operative Masonry, but from something else. Their arguments seem somewhat like those of the Greek historians who argue, that the *Iliad* and the *Odyssey* were not written by Homer, but by someone else of the same name. In this connection it is interesting to remember, that there were students of repute who seriously maintained that there never was such a city as Troy, and that Homer's poems dealt with a myth and described what had never happened.

When Dr. Schliemann discovered Troy, and found it to be at Hissarlik, where tradition had always said it was, Homer's account was largely vindicated, and as Mr. Gladstone said in an essay on Homer, "Grote condemns as pure myth or fable much that is now gradually taking historic form."

I feel quite sure that in a "Lodge of Research" such as this at Leicester, which I believe is the premier

one of its kind and second only to that great, but at times slow-moving organisation, the "Quatuor Coronati" Lodge, and where you have had the benefit of W. Bro. Thorp's teaching and editing for so many years, it is scarcely necessary to prove the Operative origin of Speculative Free Masonry.

In the last vol. of Transactions (1910-11) W. Bro. Thorp in his Addendum, "Masonic Papers No. IV.," p. 32, comments on what is an astounding fact, that is, that so *many* Brethren are absolutely ignorant of the version of the "Old Charges" which is printed in the present Book of Constitutions. It has been my lot to point out these Old Charges to scores who have frankly admitted they did not know they were there.

Bro. Thorp goes on to say, "This want of knowledge is very much to be regretted, inasmuch as these 'Old Charges' are an interesting link with an honourable past, tending to remind us of our connection with the Operative Masons of olden times, who beautified the land with so many stately and superb edifices." So that if any one still doubts the fact that the formation of Speculative Free Masonry was due to, and based upon Operative Free Masonry, it is quite easy to convince him of his error from our present Book of Constitutions.

In spite of many alterations and additions, and of its complete revisal at the Union of 1813, it shows unmistakably its Operative origin.

These very same Ancient Charges, given on pp. 1-15, and to which I have already drawn your attention when quoting W. Bro. Thorp's remarks, are almost identical with the Ancient Charges given in the first Book of Constitutions published in 1723. The alterations are very few and unimportant, and there are none in sec-

tion 5, which is the one I rely upon. This section has for title, "Of the Management of the Craft in Working," and I want you to carefully read it, and you will find it is obviously and solely Operative in its terms.

Among the principal arguments upon which I rely, to prove that the formation of Speculative Free Masonry was due to, and based upon Operative Free Masonry, are:—

(1). The First Book of Constitutions prepared by Anderson, and printed and published by the authority of the Grand Lodge in 1723.

(a). In the Introduction, J. T. Desaguliers says, "I need not tell your Grace what pains our learned Author has taken in compiling and digesting this Book from the old Records."

(b). In the Approbation, p. 89, it reads: "And our late Worthy Grand Master, his Grace the Duke of Montagu, having ordered the Author to peruse, convert and digest into a new and better method, the History Charges and Regulations of the ancient Fraternity."

(2). The New Book of Constitutions by James Anderson, D.D., 1738.

"Approved by the Grand Lodge and the members order'd the Author Brother Anderson to print the same." Jan. 25th, 1738.

(a). The Author to the Reader "His Grace the present Duke of Montagu when Grand Master, order'd me to peruse the old Manuscripts, and digest the Constitutions."

(b). p. 113. "His Grace's Worship and the Lodge finding fault with all the old Copies of the old Gothic Constitutions, order'd Brother James

Anderson A.M. to digest the same in a new and better method." Sept. 29, 1721.

Surely these extracts prove that the Brethren of those early days of the Speculative Grand Lodge, believed they were concerned with the Charges and Old Constitutions of the Operative Masons, or they would not have been at such pains to record, that their Constitutions and Charges were prepared by the authority of Grand Lodge from the old ones.

(3). The Speculative Ritual also gives proof of its derivation from the Operative.

(a). In the presentation of the Working Tools in each of the Three Degrees.

"As we are not all operative masons, but rather free and accepted, or speculative."

(b). Operative Masons are referred to in the First Tracing Board when the movable Jewels are described and their uses explained.

(c). Operative Masons are described in the Official Lectures. Lecture I., Section VII., Emulation Working.

(d). In the Mark Degree the candidate desires advancement "that he may be enabled to preside over a Lodge of Operative Masons."

(4). Many leading authorities are agreed, that much of the Ritual and many of the customs of the earliest Lodges which formed the first Speculative Grand Lodge in 1717, were derived from the then existing Lodges, which Bro. Speth believes to have mainly consisted of working Masons (A.Q.C., II., 88), although all of them had some, and old No. 4 many, Speculative members.

Many Lodges other than the original four, who constituted the first Grand Lodge, subsequently joined the

new Speculative body. Here it must suffice to mention the three Cheshire Lodges which joined in 1724, and to point out that the Lodge of "Industry," Gateshead, and the Alwrick Lodge, which also joined, were entirely Operative in character. So that we may safely assume that the Operative customs and ritual were largely transferred. Indeed, as Gould points out, (History II., 266) so many Brethren went over that it is extremely improbable that any violent changes were made.

Having advanced perhaps a sufficiency of reasons to prove that Speculative Free Masonry is undoubtedly derived from Operative Free Masonry, it is for you to judge how far it is so highly probable, that it amounts to a practical certainty, that in the Ritual of the Operative Free Masons existing to-day, we have the same Ritual as that which existed among the Operatives two centuries ago, and from which the Speculative Ritual was then derived.

The evidence in favour of this view seems so accumulative, and so increasingly weighty, that it amounts to such proof as would be accepted by an average man, in the conduct of his own business affairs, and the ordinary matters of daily life.

That the origin of the Operative Ritual reaches very far back is substantiated by its own internal evidence, which is to me the greatest of all proofs. It has reference to Star Worship in its reference to the Pole Star, to Sun Worship in its Salutation of the Rising Sun, and to Fire Worship on high places by the lights on the three pillars which represent Moriah, Tabor and Sinai.

One is told that is only tradition; one must not forget that tradition existed long before written history, and this would be peculiarly so in the case of secrets which

it was not lawful to write. The oldest and some of the best books in the world were handed down to us by tradition, long before they were written; and our English Common Law is still a matter of tradition and is unwritten to this day.

CONCLUSION.

The Ritual of the Operatives is more archaic in form and is much fuller than is that of the Speculatives, and contains practical instruction of which only the echoes are found in the Speculative Ritual.

Nearly all the Speculative teaching can be traced to the Operative ceremonies, but there is much of the Operative teaching which has no correspondence in the Speculative ceremonies.

Then the reason for much of the Speculative ceremonies can be seen in the Operative Rituals, while the Operative ceremonies get no elucidation from the Speculative Ritual. I would specially draw your attention to the obligation in the First Degree, in which the Operative formula contains all the Speculative does, and just enough more to show its meaning and forcefulness. I think there can be no two opinions as to which is the older form of the two, and is the original.

Then the signs and words of the Operatives are *all* connected with, and based upon, their trade, while extraneous signs and words are introduced into the Speculative system; for example, the Speculative Password from the Second to the Third Degree is really the word from the Blacksmith's Guild. I would here specially refer to the Giblim sign of the expert craftsman of the Second Degree, and to the VII. Degree signs and secrets; added to which, the Operative ceremonies are

actual and concrete, and refer to realities, while the Speculative ceremonies and allusions are symbolic and abstract, and refer to idealities. The actual must precede the symbolic for it to have reference and meaning, and the concrete must exist before the abstract can be conceived. The real exists before the ideal can be built upon it.

To any who will compare the two Rituals, and the internal evidence of each, there can be no question as to which is the elder and original, quite irrespective of tradition, and of the fact that the older body, the Operative, is using ceremonial forms which are admittedly the same as those of the 17th Century, of *at least* fifty years before the formation of Speculative Free Masonry in 1717.

Surely if any Brother did not know or doubted the fact that the Speculative system is irrefutably based upon, and has many deep resemblances to, Operative Free Masonry, he must now be convinced.

Findel, the great German writer, in "The History of Free Masonry," published so long ago as 1865, puts my own conclusions most forcibly, when he says, "Originating from the Fraternity of Operative Masons, the Craft has borrowed its emblems and symbols from the Building Corporations, to impart to its members moral truths and the rules of the Royal Art." And again, speaking of the increase of the Speculative element, "Then it was that Freemasonry, as it is understood at the present day, dawned into existence, retaining the spirit of the Ancient Brotherhood, their fundamental laws and their traditional customs, yet all were united in relegating Architecture and Operative Masonry to the station to which they belonged. The customary technical expressions, which

were excellently well suited to the symbolic Architecture of a Temple, were retained, but figuratively, withal bearing a higher signification."

In conclusion, I must express my gratitude to the Worshipful Society of Operative Free Masons of the York Division, for their patient instruction in the technical work and ritual of their ceremonies. I also gratefully testify to the brotherly regard and desire for the extension of knowledge, which has alone led them to give me permission to publish so much of their working and of their secrets.

Personally, I sincerely regret and deeply deplore the fact, that trade unionism and modern conditions of trade have caused the decay and threaten the existence of so useful, ancient and honourable a society; but am highly gratified at having been selected as the medium to make their present existence and condition more widely known.

Possibly the Operative Guild of Free Masons, which has continued down to the present day, may be doomed to extinction; but their history will ever live and their memory ever be perpetuated by their undoubted successors, the Speculative Free Masons, whose proper title is "The Ancient Fraternity of Free and Accepted Masons."

The WORSHIPFUL MASTER asked if the Brethren wished to offer any remarks.

Bro. THORP desired to express the hearty thanks of the Brethren for the very excellent and interesting Paper, which he was sure would create a deep impression; he mentioned that a Swastika had been recently discovered in the wilds of Siberia. He moved a Hearty Vote

of Thanks to the lecturer, and expressed the hope that the Brethren would hear him again ere long.

The WORSHIPFUL MASTER seconded the resolution, supplementing Bro. THORP'S remarks by an appeal for permission to publish the Paper in the Lodge Transactions.

The resolution was carried unanimously.

Bro. CARR, in responding, said it had been a labour of love, and gave his consent to the publication.

Bro. THORP asked permission of the Brethren to consult with Bro. BILLSON, Treasurer, in the matter of the expenses to be incurred in the publication of the re-issue of Bro. HUGHAN'S book on "The Old Charges." On the proposition of the W.M., seconded by Bro. A. LOLE, this was unanimously accorded.

The following apologies for non-attendance were recorded, viz. :—

Bros. F. W. CROSS (Walsall); C. L. EDWARDS (Loudwater); J. A. SHERREN (Weymouth); G. W. BAIN (Sunderland); T. TAYLOR (Newcastle-under-Lyme); T. C. BATES (Derby); J. E. CAWTHORN (Sherburn-in-Elmet); R. C. LEVERSEDGE (Bath); H. G. BURROWS (London); W. LONNON (Portsmouth); A. MARKHAM (Penarth); C. W. FRANCIS (Birmingham); J. C. MOOR (Sunderland); A. FERGUSSON (Leicester).

Hearty Good Wishes were tendered by the Visiting Brethren, and the Lodge was closed.

The One Hundred-and-Fourth Meeting

of the Lodge was held at the Freemasons' Hall, Leicester, (by Dispensation), on Monday, June 3rd, 1912. The Chair was occupied by the Worshipful Master, Bro. GEO. BONNER, P.M. 523, P.P. Gd. Std. B.

The Dispensation from the Prov. G.M. authorising the alteration in date of Meeting, was read.

The Minutes of the last Meeting were read and confirmed.

The following Brethren were unanimously elected Officers of the Lodge for the ensuing year, viz. :—

Bro. Rev. C. T. MOORE as Worshipful Master.

Bro. R. W. MARIES, Tyler.

The election of Treasurer was postponed, Bro. BILLSON having expressed his desire to be relieved from the duties of that office.

The following Paper was read :—

A Masonic Triad: Preston—Hutchinson—Oliver.

By Bro. W. B. HEXTALL, P.Pr. S.G. Warden, Derbyshire;
Hon. Member, Lodge of Research, No. 2429.

SYLLABUS.

- WILLIAM PRESTON, 1742-1818.—His Father's poem. His varied Masonic record. The "Antiquity" dispute and its consequences. Preston's *State of Facts*. *Masonic Anecdotes of Little Solomon*. *Illustrations of Masonry*. His death and benefactions.
- WILLIAM HUTCHINSON, 1732-1814.—The historian of Durham. *The Spirit of Masonry*. Noticeable passages in his works.
- DR. GEORGE OLIVER, 1782-1867.—His Father, Rev. Samuel Oliver. His Masonic career. The Apollo Lodge, Grimsby. His many published books. His farewell to the Craft in 1866.

It has been said and written that every mysterious system practised on the habitable globe contains a Triad; and one of those with whom we are to-night concerned, Dr. George Oliver, included in his *Freemasons' Treasury* (1863) a table of no less than seventy-six Masonic Triads which he illustrated and explained; whilst in his *Discrepancies of Freemasonry* (published posthumously, 1875) he formulated "qualification questions" for the three Craft degrees, divided into twenty-seven Triads. Be the intrinsic value of these what it may, certain it is that amongst authors of the old school in Freemasonry the three English Freemasons whose names head this Paper form a Triad with works extending over nearly a century—from 1772 to 1866—and of whom I now attempt rather personal sketches than an essay upon their writings.

Before Preston ventured on his *Illustrations of Masonry* in 1772, most of our masonic literature was comprised in the various editions of Anderson's Constitutions and "Pocket Companions"; in almost innumerable "Exposures," "Disclosures" and other attacks upon the Craft, some scurrilous and none of them edifying, with replies to them which were more or less convincing; a few "Charges" delivered and Sermons preached on occasions favourable to their appearance in print; Dermott's "Ahiman Rezon," 1756 and 1764; together with the volume, "A Candid Disquisition of the Principles and Practices of Masons, by Wellins Calcott, 1769." Indeed, very little can have been intelligibly known of the Craft by the body of its members down to the time when the *Illustrations of Masonry*, by William Preston, and *The Spirit of Masonry*, by William Hutchinson, first appeared, the one in 1772, and the other three years later.

WILLIAM PRESTON,* the pioneer of masonic literature in its modern sense, was born at Edinburgh, in July, 1742; the son of a writer to the signet, who gave him a good education, and is said to have died in 1751. I am not sure that this last date is correct, for there exists *A Poem to the Divine Majesty, by William Preston, late Writer to the Signet. Edinburgh. Printed by Walter Ruddiman and Co., for the Widow. . . . MDCCLVIII.* Young Preston had been placed with the Ruddimans' publishing firm, and it seems improbable that a delay of seven years should have taken place before the issue of his late father's poem, which consists

* *Vide* Plate XII.

of eighty-six lines, and hardly deserves attention on its own merits, as the following couplets from it show:—

O Being uncompounded! One, unseen,
Unbody'd, whom no Limits can contain!

Truth, without Falsehood, present ev'ry Where,
Untied, by Space, to a peculiar There.

Without Extension, Thou extend'st to all
In Heav'n and Hell, and this terrestrial Ball.

They almost invite speculation as to how far a certain turgidity, not always absent from the son's writings, was hereditary.

Young Preston appears to have found favour with his employers, and in 1760 came to London with their introduction to William Strahan, King's printer, by whom he was employed as corrector of the press, and who on his death in 1785 left him an annuity. Under Andrew Strahan, who succeeded his father, he became chief reader and general superintendent until 1804, when he was admitted partner in the firm; and that his literary capability was considerable is clear. To quote from obituary notices which appeared upon his death in 1818: "His critical skill as a corrector of the press led literary men to submit to the correction of style; and such was the success of William Preston in the construction of language, that the most distinguished among them honoured him with their friendship, as presentation copies, now in his library, of the elegant and instructive Robertson, the acute and philosophic Hume, the elegant and luminous Gibbon, the moral and philological Johnson, and the pious and polished Blair, will bear testimony."

Preston was admitted to the Craft probably on April 20th, 1763, in a Lodge then working by authority of the "Ancient" Masons, and for which a charter was afterwards granted by the regular, or "Modern," Grand Lodge, as the Caledonian Lodge. This last has been stated as having occurred in 1772, and at Preston's instance, but the late Bro. Henry Sadler, in *Masonic Facts and Fictions* (1887), p. 185, asserted that the Caledonian Lodge was in fact constituted by the "Moderns" in November, 1764, and that Preston was associated with the "Ancients" for about eighteen months only. Preston was certainly recognised as a Masonic lecturer by 1772, and in that year he published the first edition of his *Illustrations of Masonry*, in which the proceedings at "A Grand Gala in honour of Freemasonry, held at the Crown and Anchor Tavern in the Strand," on May 21st, 1772, are a feature, but were omitted in later editions. In response to his application for a sanction, the G.M., Lord Petre, and his Wardens declared, "We having perused the said Book, and finding it to correspond with the ancient practices of this Society, do recommend the same."

The year 1774 was an important one to Preston, for on June 15th, he being a visitor at the Lodge of Antiquity, No. 1, then held at the Mitre, was admitted a member and elected Master—unusual events for one day. He had already occupied the chair of several other Lodges, but now directed his energies mainly to the "Antiquity," which flourished exceedingly, and his mastership is stated to have continued for some years. In 1775 the *Illustrations* attained a second edition, which differed in many respects from the first, and the form of which all later issues have followed. At the commencement

is printed a letter and minute from the King's Arms Lodge, Falmouth, of July, 1773, conveying formal thanks to Preston for his first edition, which it describes as "his very ingenious and elegant pamphlet." The second edition had the advantage of an advertisement in the printed proceedings of Grand Lodge for November, 1776.

At Grand Lodge, in November, 1775, the publication of an appendix to the existing Constitutions (of 1767), and the issue of a Freemasons' Calendar, were resolved upon; and these were compiled by Preston, who had become Deputy Grand Secretary, and was by now well known to the English Craft.

I must pass rapidly over the details of the dispute which arose upon the subject of a Masonic procession by the Lodge of Antiquity, in December, 1777, and led to much acrimony and recrimination, in the course of which Preston produced his *State of Facts: being a narrative of some late proceedings in the Society of Free Masons, respecting William Preston, Past Master of the Lodge of Antiquity, No. 1. . . . London: printed in the year MDCCLXXVIII.*; the title of which I have quoted in full, as it was privately printed by Preston for his friends, and from its great rarity is now a desideratum to collectors. The preface is dated 3rd June, 1778, and this pamphlet of 88 pages affords some curious reading, and exhibits its author as a very militant disputant. In it, he claims to have introduced 300 members to the Society, and says, "I have been employed upwards of fourteen years in establishing a system for the honour of the Society, in the course of which I have consulted the best authors, both ancient and modern. I have now in my possession extracts from above 2000 volumes on the

subject. These I intend to arrange under the title of *Adversaria*, and publish under sanction, with a few cursory observations; but the present dispute, I believe, has effectually baffled my intention." He also mentions, "A Digest of all the Laws which have subsisted since the establishment of the Grand Lodge; a work I have long had in contemplation." In his pamphlet, Preston accuses one person of "duplicity—having before professed himself my friend in order to take advantage of my open disposition"; imputes to another that he "had been honoured with a blue apron and thought it necessary to make his dignity conspicuous"; waxes sarcastic, "The Society is surely highly honoured by the wisdom of such directors!"; refers to "the spirit of Mr. Noorthouck—of a piece with his low and illiberal abuse"; and says of the Grand Secretary (Heseltine), "lest the fire should be put out, he was pouring a torrent of inflammatory matter to rekindle it." It is pleasanter to turn to Preston's concluding lines, "To the institution of Masonry, I shall ever bear a warm and unfeigned attachment; I know its value, I am convinced of its utility.—To the Society of Free Masons, I profess myself a true and stedfast friend."

The progress and outcome of the dispute have been several times related, and I need only say here that although ostensibly, and probably in reality in the first instance, the *casus belli* was an attempt to claim inherent and unconstitutional rights for the Lodge of Antiquity, Preston's attitude seems to have been a good deal influenced by personal antagonisms which are known to have existed between himself and prominent brethren of the time. He had been a joining member of the Grand Lodge at York since 1774, and in September, 1778, he

and other members of "Antiquity" conceived and carried out the daring project of applying to York for a Deputation "to act as a Grand Lodge throughout that part of England which is situated South of the River Trent"; following this with the issue, in December, of a "Manifesto" by the Lodge of Antiquity, solemnly acknowledging the authority of the Grand Lodge at York "as the truly ancient and only regular governing Grand Lodge of Masons in England," and repudiating what it was pleased to call "the Nominal Grand Lodge in London"; after which it is hardly surprising that Preston and ten of his associates were expelled by the Grand Lodge at London in January, 1779. Whether he was quite fairly treated as to methods may be open to question; but it was a period of much difficulty for the Grand Lodge, which had so recently as April, 1777, passed a formal resolution directed against the proceedings of the "Antient" or "Athol" Freemasons; and Preston's conduct had been provocative in the highest degree.

In October, 1778, Preston's *State of Facts* had been stigmatized at the Committee of Charity as containing "many severe, inflammatory and false Reflections" upon Grand Lodge and its Secretary; and after the expulsion a further pamphlet appeared, in which it is likely that Preston had a hand, though another name was upon it.* The Deputation was granted from York in March, 1779, and the "Grand Lodge of England South of the Trent" maintained a nominal existence for ten years, its whole record being the chartering of a couple of London Lodges, in August and November, 1779.†

* *Gould*, II., 425ⁿ, 426.

† Lane's *Masonic Records* (1886), 3.

Whilst under suspension, Preston appears to have rarely or ever attended any meetings of the Society, though he remained member of many Lodges, at home and abroad; and one account of his career quaintly says, "he directed his attention to literary pursuits, which may fairly be supposed to have contributed more to the advantage of his fortune."* A folio pamphlet, without date or name of printer, entitled, "*Masonic Anecdotes of Little Solomon: A Caution to the Fraternity . . .*"† dealt very candidly with Preston at this stage of his career. After narrating the events leading up to his expulsion, and asserting that, "He was ever of a restless Disposition, and Inventing New Modes and Customs among Masons, and endeavouring by every Art and Cunning in his power to run counter to the Society, and to introduce Schism," it goes on, "Now . . . what did Little Solomon do upon being expelled? He obtained (or pretended he had obtained) a Warrant or Constitution to himself and others to set up a Grand Lodge, under the Sanction of York Masons, which he did. . . . Little Solomon soon found himself deserted by his friends the Yorkists. His attempt of Opposing the Grand Lodge of England under the name of York Masons dropped; and Little Solomon once more became a Sojourner and wandered about in search of Materials for building another Temple of mischief. . . . Little Solomon; . . . contented himself with Visiting Lodges of Instruction for some time; but that being of too

* *Edinburgh Magazine*, May, 1811.

† A copy is in the Library of *Quatuor Coronati* Lodge, No. 2676, London.

‡ "Little Solomon," as Preston was called by some of his opponents. —Sadler's *Masonic Facts and Fictions* (1887), 192.

innocent a Nature, and too quiet for his restless Disposition, he soon turned his thoughts how to render the Ancient & Honourable Society of Free and Accepted Masons uneasy, and to introduce a further Schism he set up a new Society under the name of 'The Antient and Venerable Order of Harodim . . . under the General Direction of Brother William Preston, Past Master of the Lodge of Antiquity, acting by Immemorial Constitution.' Under this Title, and by this Impudence and Deceit, he got together a number of Masons to attend him. Little Solomon, flattered with the Attention paid him by Brethren not acquainted with his Deceit, Inconsistency and Duplicity, has at length thrown off the Mask, and not only published an Advertisement in the Morning Herald of the 17th of January 1787, but also distributed Hand-bills purporting 'That the Lodge of Antiquity, acting by Immemorial Constitution, was removed to . . . And still continued to initiate Gentlemen into the different degrees of the Order, according to ancient usage and custom, and they were informed there was a Lodge of modern date, under the patronage of the Grand Lodge in Great Queen-street, which had assumed the title of that Lodge.' For which, and for the following among other reasons it is hoped that all regular Masons will withdraw their Names and themselves from Associating with, or in any manner giving countenance to, so great an Imposter, Dissembler, and Contemner of our Excellent Laws and Constitution:

1. Because he is Expelled the Grand Lodge.
2. Because from the time of his Expulsion every act that he has done has been irregular and without any Constitution from the Grand Lodge.

3. Because he has now, exclusive of his New Antient and Venerable Order of Harodim, attempted to establish a Lodge of Freemasons . . . where he makes Masons without any Constitution.
4. Because he stiles his Lodge the Lodge of Antiquity, 'Constituted Time Immemorial,' by which means he reflects upon the real Lodge of Antiquity No. 1, held under the Constitution of England, by calling it a pretended Lodge, acting under the Grand Lodge held in Great Queen-street.

Under all the circumstances of the Case, it is submitted that no regular Masons, having any regard to their character or consistency, can or will associate with a Man who has acted in the way Little Solomon has done, as in all probability if complaint was made to the Grand Lodge of the Brethren so associating with him, they might be Expelled the Society, and the Constitution of their respective Lodges be endangered."

This genial production ended with the signature, "Bonia Menatzchim." Speculation as to its authorship would now be in vain, but it must have accorded with views which were officially held, and have tended to keep alive the feeling against Preston which had continued since the dispute of 1778; and as the "Little Solomon" publication could not be earlier than 1787, it probably contributed to the temporary non-success of a memorial by Preston which in April, 1789, Grand Lodge would not allow even to be read. However, a month afterwards, on May 4, 1789, Preston and others, who had been expelled with him and not yet re-admitted, upon "signifying their concern that through misrepresentation, they should have incurred the displeasure of Grand

Lodge . . . to the laws of which they were ready to conform," were ordered by Grand Lodge, which was "satisfied with their apology," to be restored to their privileges in the Society. As Grand Lodge had maintained its firm and consistent attitude throughout, whilst the pretensions advanced for the Lodge of Antiquity were withdrawn, and a sponge was passed over all that related to the "Grand Lodge of England South of the Trent," the final result was decisive in favour of the properly constituted authority.

A contemporary notice of Preston in the *European Magazine* for 1811 gives this account of his labours in connection with the Masonic Lectures subsequently to his Grand Gala in 1772:—"He determined to prosecute the plan he had formed, and to complete the Lectures. He employed, therefore, a number of skilful brethren, at his own expense, to visit different town and country Lodges for the purpose of gaining information, and these brethren communicated the result of their visits at a weekly meeting. When, by study and application, he had arranged his system, he issued proposals for a regular course of Lectures in the different degrees, and these were publicly delivered by him at the Mitre Tavern, in Fleet Street, in 1774." Dr. Oliver wrote, in 1850,⁹ that Hutchinson and Preston "each engaged in the meritorious design of improving the existing Lectures, without being conscious that his worthy contemporary was pursuing the same track. There are reasons for believing that they subsequently coalesced, and produced a joint Lecture which . . . was at length adopted and carried into operation by the concurrent usage of the whole fraternity. This course

⁹*The Symbol of Glory*, 20

of Lectures was in practice till the re-union in 1813, and I believe there are still many Lodges who prefer them to the Hemming or Union Lectures, and still continue their use."

The life of Preston after his restoration to the Craft in May, 1789, was comparatively uneventful. In 1787 he had taken a principal part in forming the "Grand Chapter of Harodim," which was in substance a Lodge of Instruction, but had a comparatively short existence. He seems to have retained his interest in the Lodge of Antiquity, and upon the Duke of Sussex accepting the chair of that Lodge in 1809, Preston was honoured by being appointed Deputy Master; and was also one of six Past Masters who were invested by the Duke with an honorary medal. It has been noticed that, considering Preston's long and intimate connection with the Lodge of Antiquity, and the extent to which the latter's ritual influenced the Special Lodge of Promulgation formed in 1809 to settle Craft ceremonial, it appears strange that he was never a member of the body on which that responsible duty devolved.⁹

The *Illustrations of Masonry*, which will form Preston's lasting memorial, have gone through seventeen English editions. Dr. Oliver's preface to the last, in 1861, states that the work "forms the basis of several Masonic publications in the United States, and some of them, including Webb's Monitor, were compiled verbatim from its pages." Preston's career affords so much of personal interest, and his *Illustrations* are so widely known, that I spare you any detailed description of the work. To quote from the *Freemasons' Magazine*, 1861, p. 327, "It was William Preston who first produced a readable

* A. Q. C., xxiii., 59.

commentary on the general manners, customs, usages, laws, government and history of the Order."* Proof of the popularity of *Illustrations of Masonry* is found in the circumstance that copies were acquired by Lodges and regarded almost as indispensable as the Book of Constitutions.† All the issues from the third (1781) to the twelfth (1812), which was the last published during Preston's life, give his address as "Dean Street, Fetter Lane." Beyond the works already named, I know of no published writings by Preston except a vigorous defence of the Craft which appeared in the *Gentleman's Magazine* for August, 1794, signed "A P.M. of the Lodge of Antiquity," and was reprinted in Stephen Jones's *Masonic Miscellanies*, 1797 and 1811.

After an illness of nearly five years, Preston died on April 1st, 1818, in his 76th year, and was buried at St. Paul's Cathedral. I have met with no mention of his being married. He bequeathed £1,300 in Consols to be distributed—£500 to the Charity Fund of Grand Lodge; £500 to the Female Charity School; and the interest of £300 for the annual delivery of "a Lecture on the First, Second, or Third Degrees of the Order of Masonry, according to the system pursued in the Lodge of Antiquity during my Mastership." This last was intended to endow and perpetuate the "Prestonian Lecture," which was regularly delivered until 1855, but has been wholly discontinued since 1862.

* For criticisms on some of Preston's historic methods, see a Paper by Bro. R. F. Gould on "Degrees" in A.Q.C., XVI., 28.

† In 1773 the *Illustrations of Masonry*, and in 1776 *The Spirit of Masonry*, were acquired by the Apollo Lodge at York (Hughan's *The Apollo Lodge, York*, 1889, pp. 27, 43.) The writer has the *Illustrations*, 9th edit., 1796, in a binding which shows it belonged to the Mariners' Lodge, Selby (1799-1822) as No. 2. No. 1 in their library would doubtless be Anderson's *Constitutions*, 1784.

There is an engraved portrait of Preston in advanced life in the *European Magazine* for May, 1811, and in the *Illustrations of Masonry*, editions of 1812 and 1821; and there is also a large separate print representing him as a much younger man. Of both these, paintings now at Freemasons' Hall are probably the originals.

Three years after the appearance of Preston's *Illustrations*, and in the year which saw its second edition, there was issued *The Spirit of Masonry, in Moral and Elucidatory Lectures*. By WILLIAM HUTCHINSON,* *Master of the Barnardcastle Lodge of Concord*. London, 1775; having prefixed to it a formal sanction by Lord Petre, G.M., and his officers, in almost the same terms as that accorded to Preston. It is a coincidence that the issues of both Preston's and Hutchinson's books in 1775 were made by apparently the same publisher, Wilkie, of St. Paul's Churchyard.

Unlike Preston, there is little that was eventful to be found in the life and career of Hutchinson. Born in 1732, he lived his life at Barnard Castle, practising as an attorney, and being Clerk to the Lieutenancy of Durham, and a F.S.A. His *History and Antiquities of the County Palatine of Durham*, 1785-1794, is a standard work, but proved of small profit to the author, who sold for a small sum four hundred of the thousand copies printed to John Nichols; two hundred of these became waste paper, and most of the remainder were burned, with Nichols' printing office and warehouses, in February,

* *Vide* Plate XIII.

1808.* Hutchinson wrote several other works on North of England topography, and is credited with some plays and minor fiction, besides leaving in MS. a "Poetical Sketch" of his own life, not known to have been published.

The second edition of *The Spirit of Masonry* was printed at Carlisle in 1795, and the third edition is claimed upon title pages for no less than three localities and dates—by Jollie, Carlisle, in 1802; by McEwen, Edinburgh, in 1813; and by Tegg, London, in 1815. It may be comforting to possessors of either to know that there is no substantial difference between them—they all contain large additions to the original issue of 1775.

Hutchinson's book has always been regarded with respect, though admiration it received in earlier days has suffered under the test of later criticism. Dr. Oliver, who edited a new edition of it in 1843, wrote in his preface, "The work was received with enthusiasm, as the only Masonic publication of real value then in existence. It was the first efficient attempt to explain, in a rational and scientific manner, the true philosophy of the Order. . . . In this book he gives to the science its proper value. After explaining his design, he enters copiously on the rites, ceremonies and institutions of ancient nations. Then he dilates on the Lodge, with its ornaments, furniture and jewels; the building of the Temple; geometry; and . . . expatiates on secrecy, charity and brotherly love [with] a description of the occupations of Masons, and a masterly defence of our rites and ceremonies. It

* This was the same fire in which so many of the rare West Goscote Hundred volume of Nichols' *History of Leicestershire* were consumed.

is truly termed *The Spirit of Masonry*, for it is replete with an interest which applies to all time." Later writers have said that Hutchinson "was beset with theories, and it is only the framework of his book which is now of value" (*Mackenzie's Royal Masonic Cyclopaedia*, 1877); and that he "had his own peculiar theories which a later and sounder criticism has compelled Masonic students to discard. His etymology and his symbolism are both somewhat strained" (*Woodford's Masonic Cyclopaedia*, 1878). Whilst Findel, in his *History of Freemasonry*, (1871 ed., p. 365), goes further. To Hutchinson's work the *Masonic Manual* of the Rev. Jonathan Ashe, D.D. (1813 and 1825), as well as other books, is largely indebted.

Included in the second and later editions of *The Spirit of Masonry* are some "Orations," one of which, *An Oration delivered at the dedication of a new Free-Masons Hall*, contains passages upon the Orders of Architecture, which are worth comparing with portions of our second Craft Lecture, section four, and may indicate a source whence the latter were derived. Hutchinson claims that his *Spirit of Masonry* was original, being "Lectures composed for the use of the Lodge over which I have presided for several successive years, [with] explanatory notes, to support my propositions, or exemplify the principles of the work." On the occasion of an Oration at Rokeby Bridge, in June, 1773, Hutchinson, "Master of the Lodge, took his place in the procession dressed in white and gold"; and another of his Orations, at the dedication of Free-Masons Hall, Sunderland, in July, 1778, has been styled "a modest and elegant account of the Origin, Principles, and Conduct of the Free Masons."

I have elsewhere pointed out* that though Hutchinson's interpretation of the Craft is in the main spiritual, he wrote that the letter G. "denotes Geometry, which to artificers is the science by which all their labours are calculated and formed."

William Hutchinson died at Barnard Castle, in April, 1814, aged 82, surviving his wife a few days only, and leaving three daughters and a son. An inquiry in *Notes and Queries* so lately as 1905, respecting his descendants, remained unanswered.

Hutchinson's portrait, on the same plate as that of George Allan, a fellow F.S.A., who furnished much material for the *History of Durham*, is in Nichols' *Literary Anecdotes*, Vol. VIII. (1814), and from this plate portraits of Hutchinson contained in one or two issues of *The Spirit of Masonry*, have been taken. It was engraved at Allan's expense and intended as a frontispiece for the *History of Durham*, but not so used; and was afterwards issued with Nichols' 1814 imprint. Allan's son wrote of it, "Better likenesses never were exhibited, although the original picture was painted by an itinerant artist."

Turning from two authors whose reputations rest principally upon a single book, to a later and far more prolific writer. GEORGE OLIVER† was son of the Rev. Samuel Oliver, who was probably born soon after 1750, became Head Master of Lutterworth School, and was initiated in St. John's Lodge, Leicester, in 1797. I will here digress to add to references to this ancient

* In a Paper on "The Old Landmarks of the Craft," A.Q.C. XXV.

† *Vide* Plate XIV.

brother, which will be found in Bro. J. T. Thorp's *Masonic Papers*, 1901, and in "Research" *Transactions*, 1906-7, the circumstance that upon the publication of *A Masonic Sermon preached in St. John's Church, Peterborough, July 26, 1802, Being the Day appointed for the Consecration of the Lodge of St. Peter, in that City, By Brother The Revd. S. Oliver, R.A.M., Chaplain to the said Lodge*, the following from St. John's Lodge, Leicester, No. 471, subscribed for copies:—Bros. Luck, R.W.M.; J. Caparn, W.S.W.; J. Smith, W.J.W.; J. B. Smith, W. Sec.; W. Burley, W.P.M.; W. Cornish, W. Richardson, J. Abbey (Steward), H. Gird, H. Clay, T. Shenstone, J. Cook, J. P. Tailby, J. Willis, R. Bond, R. Clarke and J. Billson. Bro. Samuel Oliver became curate of Whaplode, Lincs., in 1801, and so remained until 1842, when he was presented to the rectory of Lambley, Notts. He died in 1843.

The son, George Oliver, was born near Nottingham in 1782, became Second Master of the Grammar School at Caistor in 1803, and Head Master of that at Great Grimsby in 1809; and was admitted to the Craft in St. Peter's Lodge, Peterborough, by dispensation, being then under age. It is curious that the precise date is unknown, nothing more than that it occurred "about the year 1802-03" being ascertainable.*

His first known display of Masonic energy seems to have been the removal of the warrant, and purchase of the furniture, of St. James's Lodge, Louth, to Grimsby, where a new Lodge was in 1813 dedicated as the "Apollo," and at once entered upon a successful career, which lasted until it ceased working in 1829; Oliver returning the warrant to Grand Lodge in 1834. After

* Dixon's *Freemasonry in Lincolnshire* (1894), 282.

being ordained deacon and priest, he received the living of Clee in 1815, and was appointed surrogate. In 1831 he became rector of Scopwick, Lincs., which he held till his death, and from 1834 to 1846 was sacrist of St. Peter's Church, Wolverhampton, which last he vacated upon being presented to the rectory of South Hykeham, Lincs. In 1836 the Lambeth degree of D.D. had been conferred upon Oliver; and about 1854 failure of voice compelled him to leave much of his parochial work to curates, from that time passing most of his time in retirement at Lincoln, where he died, after a fortnight's illness, in March, 1867, at the age of 84, and was buried in St. Swithin's Cemetery, with Masonic rites. A memorial window to him was placed in South Hykeham Church by a subscription of the Craft.

Oliver held provincial office in Lincolnshire as Grand Steward in 1814; Grand Chaplain in 1816; and from 1833 to 1842 was Deputy Provincial Grand Master under Mr. Charles Tennyson D'Eynecourt, M.P., P.G.M. 1827-1849. Early in 1842 Dr. Oliver presided at a dinner in London in honour of Dr. R. T. Crucefix, a medical practitioner, and prominent in the Craft, but not always judicious or restrained in his methods, who had incurred the displeasure of Grand Lodge and been temporarily suspended from masonic privileges. Inspired, as was freely alleged at the time, from head-quarters, the Prov. G.M. appointed a new D.P.G.M. for Lincolnshire, thus removing Dr. Oliver from that position. A widespread feeling of sympathy was the result, and Oliver, whose own account of the circumstances may be read in *F.Q. Review*, 1842, pp. 198-205, was presented with a silver cup and service, subscribed for by the Craft at large.

Some personal traits of Dr. Oliver are given in *Freemasonry in Grimsby*, by Bro. Anderson Bates (1892), which says that Oliver, who had been initiated in a "regular" Lodge, did not care to join an "ancient" Lodge which is asserted to have been in existence when he went to Grimsby, to this being attributed his establishment of the "Apollo"; and that the Lodge room was fitted with a long table at which the Wardens and Secretary sat in chairs (the Secretary at the east end), and the brethren on benches with backs: the Lodge being always called from labour to refreshment, when the Master left his chair upon a dais, and sat at the east end of the table, the Secretary giving place to him. Rum-punch was placed in bowls upon the table, and harmony prevailed until ten o'clock, when labour was resumed, and the Lodge closed in proper form. Many of the brethren were real sons of Apollo, and Dr. Oliver was a devoted musician. He could not only treat the brethren to a learned discourse, but he could sing a good song. He also played the violoncello. He could be both grave and gay; he sometimes sang a comic song, and the title of one of these has been preserved. The Doctor is stated to have been fourteen times master of this Apollo Lodge, which at one time numbered ninety members, showing how well it flourished under his fostering care.*

To set out the long list of Dr. Oliver's published works here is unnecessary. His industry was not confined to masonic subjects, and he wrote several antiquarian works relating to Lincolnshire, Staffordshire and Yorkshire.

* There is extant a copy of Oliver's *Antiquities of Freemasonry*, 1823, together with four of his sermons on Masonic occasions, 1816-1822, in what appears to be a specially bound volume with the label, "Apollo Lodge, No. 544, Gt. Grimsby," probably a presentation from the author to his Lodge.

He made unpublished collections for the history of Lincolnshire, the whereabouts, or existence, of which was in 1889 stated by his son, C. W. Oliver, to be unknown. Altogether his books appear to number thirty-two masonic, and ten topographical, original works, and he edited Preston (several times), Hutchinson, and Ashe separately; his dates of publication ranging from 1811 to 1866. His largest, though perhaps not his most important, work is *The Historical Landmarks and other Evidences of Freemasonry Explained*, 1846, which covers 1300 pages. Brethren will have their own preferences for Oliver's various books; I confess my own are given to *Institutes of Masonic Jurisprudence*, 1859; new edition (posthumous) 1874; *The Freemason's Treasury*, 1863; that pleasant mixture of fact and fable, *The Revelations of a Square*, 1855;* and *The Discrepancies of Freemasonry*, published posthumously in 1875, but stated by its author to have been mainly written in 1841. We must not forget, especially in regard to the earlier works of Oliver, that immense additions have been made to the historical materials of Freemasonry since his time; and while not underrating much that he so laboriously put forth, it is necessary to be on our guard against accepting unreservedly many assertions which passed muster in his day, and which he enunciated in perfect good faith.

A book which has often been attributed to Dr. Oliver, *Stray Leaves from a Freemason's Note-Book, by a Suffolk Rector* (1846), was not written by him.† There was a contemporary George Oliver, 1781-1861, a Roman

* The *Revelations* were published simultaneously in London and in New York; the issues being identical as to matter, but differing in form of the volume.

† The author was the Rev. Erskine Neale. See *A.Q.C.*, xviii, 50.

Catholic divine, on whom a D.D. degree was conferred by the Pope in 1844, and who wrote many antiquarian works relating to Devonshire and the West. As the identity of the two George Olivers has been confused in Allibone's Dict. Eng. Literature and elsewhere, this may profitably be noted.

Oliver married in 1805, and left five children; in June, 1842, at the dedication of a new Masonic Hall at Lincoln, there were present four generations of the family. To his son, Charles Wellington Oliver, of Bath, he dedicated the second edition of *The Book of the Lodge*, in recognition of "his zeal in behalf of Masonry, accompanied by a strict attention to constitutional authority in working the details, and a ready obedience to the edicts of the Grand Lodge."

Dr. Oliver's last public masonic appearance was in the Provincial Grand Lodge at Lincoln on May 10, 1866, when he delivered an Oration and Farewell Address, both of which were published: the "Oration" being described by himself as "an exemplification of the fact that a clergyman of the establishment, tolerably well versed in antiquarian lore, after a critical investigation of the esoteric principles of the Order for more than half a century, had found no reason to change his opinion on its unrivalled purity as an humble handmaid of religion."

The portrait of Dr. Oliver which appears in *F.Q. Review*, 1840, and in his *Historical Landmarks* (1846), was published as a separate plate in enlarged and slightly different form; and a photograph of him at an advanced age is prefixed to some copies of the "Oration" at Lincoln in May, 1866.

Though since the days of our three authors material has become available for masonic history which super-

sedes, or renders inapplicable, much that they wrote, their works remain with us as classics; and I trust my collected notes upon these well-known members of the Craft will not be found uninteresting.

The WORSHIPFUL MASTER expressed his appreciation of the Paper, and proposed a hearty Vote of Thanks to the Lecturer. Bro. THORP, in seconding the proposition, stated that some time back he was in Barnard Castle and searched for the grave of William Hutchinson, but without success. He regretted to find that such a literary Mason as he, was practically unknown in the district. The D.P.G.M., W. Bro. E. HOLMES, also added a few words expressive of his appreciation of the Paper. The vote was passed unanimously, in acknowledging which, Bro. HEXTALL gave his consent to the publication of his Paper in the Transactions.

Bro. J. T. THORP, P.M., exhibited and described the following Masonic curios from his own collection, viz. :—

- (1). Portrait of William Preston.
- (2). Copy of the First Edition of Preston's "Illustrations of Masonry," 1772.
- (3). Copy of the First Edition of Hutchinson's "Spirit of Masonry," 1775.
- (4). Oration and Farewell Address of Dr. George Oliver, with portrait and autograph, 1866.
- (5). French Apron, Craft and Rose Croix emblems painted on silk; early 19th century.

(6). French Apron, Craft emblems embroidered on satin; 19th century.

(7). Centenary Festival Souvenir of "British" Lodge, No. 334 Cape Town; 1911.

(8). Certificate issued by "British" Lodge, Cape Town, in 1831.

(9). Certificate issued in 1836 by Lodge "Triple Esperance," of Mauritius, to an initiate of the "British" Lodge, Cape Town.

(10). Jewel of "Royal Somerset House and Inverness" Lodge, No. 4 London.

A Letter was read from the Librarian of the Grand Lodge of Pennsylvania, stating that he had recently obtained the Warrant of the Lodge granted to the 17th Regiment of Foot (Leicester), by the Grand Lodge of Scotland in 1771, and that a print of the same could be obtained by payment of five dollars. Bro. BILLSON proposed that a copy be purchased, which was seconded by Bro. LOLE and was carried unanimously.

W. Bro. HEXTALL exhibited a Seal with Masonic emblems, probably an old Leicestershire Relic belonging to the Ortons of Hinckley.

The following communications were read:—

(1). Report of Leicester Freemasons' Hall Library Committee.

(2). Letter from Grand Secretary of the Grand Lodge of Ireland.

Apologies for non-attendance at the Meeting were received from Bros. F. W. CROSS (Walsall); R. W. STRICKLAND (Northampton); R. C. LEVERSEDGE (Bath); W. LONNON (Portsmouth); Revd. W. W. COVEY-CRUMP (Wisbech); W. N. CHEESEMAN (Selby); J. C. MOOR (Sunderland); Major JOHN BOOTH, Grand Treas., Eng.; FRANK HUGHES (Handsworth); H. J. GRACE, Sec.; H. G. MARRIOTT; C. A. FLINT; T. G. HUNT.

Hearty Good Wishes were tendered by the Visiting Brethren, and the Lodge was closed.

**The Royal Somerset House and Inverness
Lodge,
No 4 London.***

Number Four is the Junior of the four Lodges, which united early in the eighteenth century to constitute the premier Grand Lodge of England. At that time it met at the "Rummer and Grapes" Tavern, Westminster, and subsequently at the "Horn," being known by the latter name for a long period. The Lodge was erased April 3rd, 1747, by order of Grand Lodge, but reinstated September 4th, 1751, out of respect to one of their old Past Masters, viz., M.W. Bro. George Payne, P.G.M. The Lodge really represents three Lodges, viz. (a) The "Old Horn" (*Time Immemorial*); (b) The "Somerset House" (Warranted in 1762, as No. 279), with which it united January 10th, 1774, and (c) the "Royal Inverness," 648, constituted A.D. 1814, which completed the trio November 25th, 1828.

No reference in its present title is made to the "Old Horn," from which the special position of the Lodge as No. 4 is derived, although the fact of its early origin is noticed on the Medal.

The original number distinguishing the Lodge was *four*, but by the lapse of Number Two, and the Third on the Roll having come under a "*New Constitution*," it was raised to the dignity of Second, from 1740,

* *Vide* Plate XV.

continuing so until the "Blessed Union," when (as we have already seen) the Lodge again returned to its original number.

The Medal of No. 4 is oval in shape. *Obverse*.—Arms and Coronet of His Grace the Duke of Somerset in gold, on garter blue enamel. *Inscription*.—"ROYAL SOMERSET HOUSE AND INVERNESS LODGE." *Reverse*.—A Horn in gold, on a riband, "IMMEMORIAL CONSTITUTION," and the words "UNITED WITH THE OLD HORN LODGE, NO. 2, 10 JANUARY, 1774," enclosing the whole. On the rim (engraved) "Royal Inverness Lodge, No. 648. The first Lodge consecrated under the United Grand Lodge by the M.W. the G.M. H.R.H. the Duke of Sussex, 1814."

It is not known under what circumstances this Medal (or Jewel) was adopted by the Lodge to be worn by all its members, but prior to the "Union," it was not uncommon for special Jewels to be worn in Lodge, without any authority from the Grand Lodge.

(Partly taken from Hughan's "Masonic Register.")

Operative Free Masonry.

(Supplement to Paper, pp. 37-63).

For several centuries the Operative Craft has been most particular that no Apprentice should be obtained by fraud, but should know beforehand exactly what the Bond was, that he would be called upon to sign. Any young man who wishes to be made an Apprentice to the Craft of Free Mason is expected to know, and has the right to demand to know, something of the Craft before he decides to fill up Form A. (Transactions 1909-10, p. 81).

The Candidate, accompanied by at least two Apprentices to the Craft, attends at the office of the Super-intendent of the work, who gives him all necessary information about the ancient usages and established customs of the Society. If he is satisfied he signs Form A. and makes his application; if not, then the matter is at an end.

The following is the Indenture, which binds the Apprentice to his Masters:—

“This Indenture witnesseth that.....
of.....doth put himself Apprentice to the

Masters of The Worshipful Society of Free Masons, Rough Masons, Wallers, Slaters, Paviers, Plaisterers and Bricklayers (York Division), to learn their Art, and with them, after the manner of an Apprentice, to serve from the day of the date hereof until the full end and term of Seven Years from thence next ensuing and fully to be compleated and ended; during which term the said Apprentice his said Masters faithfully shall and will them serve, their secrets keep, lawful commands every where gladly do; he shall do no damage to his said Masters nor see it to be done of others, but to his power shall let, or forthwith give notice to his said Masters of the same; the goods of his said Masters he shall not waste, nor lend them unlawfully to any; hurt to his said Masters he shall not do, cause or procure to be done; he shall neither buy nor sell without his said Masters' leave. Taverns, Inns or Ale-houses he shall not haunt; at Cards, Dice, Tables, or any other unlawful game he shall not play, nor from the service of his said Masters day or night shall absent himself, but in all things, as an honest and faithful Apprentice, shall and will demean and behave himself towards his said Masters and all theirs during all the said term.

And his said Masters (and their successors from time to time) the said Apprentice in the Art and Mystery of a Mason, which they now use, shall teach and instruct or cause to be taught and instructed in the best way and manner that they can, finding and allowing unto their said Apprentice sufficient meat, drink, washing, lodging, and all other necessaries during the said term, and one pair of new shoes yearly and aprons.

And for the true performance of all and every the Covenants and Agreements aforesaid, either of the said.

parties bindeth himself and themselves unto the other firmly by these Presents.

In witness whereof the parties above-said to these Indentures interchangeably have set their hands and Seals the.....day of.....in the Year of our Lord One Thousand Eight Hundred and.....

Signed, sealed and delivered by the above named in the presence of
 Witness.

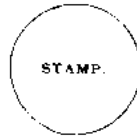

The following is a copy of the Certificate issued to Apprentices:—

LODGE "MOUNT TOR" No. 70,
 CROMFORD, DERBYSHIRE.

THESE ARE TO CERTIFY that Brother..... of.....Age.....was admitted as an Indentured Apprentice to the Craft of Free Mason in this Lodge, known by the name of Lodge "Mount Tor," being No. 70, York Division, held at The Free Masons' Arms House, Cromford, Derbyshire, on..... the.....day of.....A.D.....to serve from the day of the date hereof until the full end and term of Seven Years.

And as such we do hereby recommend him to the Brethren of all Lodges of the Worshipful Society of Free Masons abovesaid, to be admitted by them (after

due examination) to all those parts of the Mistries and Ceremonies thereof which belong unto him.

And that no profane hands may make any ill use hereof and to prevent any imposture, we have caused our Brother to subscribe his own name, so that causing the Bearer herewith to write his own name a judgment may be formed whether this be his own Certificate.

*Signature
of Apprentice.*

Given under our hands and the Seal of the Lodge abovesaid thisday of.....A.D.....



.....1st Master Mason VII°
2nd Master Mason VII°
3rd Master Mason VII°
Clerk to the abovesaid Lodge.
 Registrar.

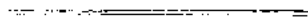

In Memoriam.

"Our life is but a step in dusty day."

Bro. General SAMUEL CROCKER LAWRENCE, of Boston (U.S.A.), died September 24th, 1911. He joined the Cor. Cir. in 1896.

Bro. HENRY SADLER, Grand Tyler and Librarian, died October 15th, 1911, aged 70. He was an Honorary Member of the Lodge. His great knowledge of Masonic History, his readiness at all times to impart information and render any assistance to members of the Craft, had endeared him to all the Brethren with whom he came in contact. This Lodge has much cause to mourn his decease.

Bro. E. T. DOVER, P.M., P.Z., Rangoon, died in 1911. His membership of the Cor. Cir. dated from September, 1905.

Bro. HY. FREDERICK, Sheffield, who died February 19th, 1912, was a member of the Cor. Cir. from 1900.

"Dear, beautiful Death! the jewel of the just."

Table of Contents.

	PAGE
ADDRESS TO MEMBERS	1
LIST OF OFFICERS AND MEMBERS	5
PAPER:—"OPERATIVE FREEMASONRY." C. E. STRETTON	37
„ "HISTORY AND SYMBOLISM OF THE THIRD T.B. REV. W. W. COVEY CRUMP.....	86
„ "OPERATIVE FREEMASONS AND OP- ERATIVE FREEMASONRY." DR. T. CARR.....	111
„ "A MASONIC TRIAD: PRESTON— HUTCHINSON — OLIVER." W. B. HEXTALL.....	141
NOTE:—"AN ANTIQUE APRON"	29
„ "THE BRITISH LODGE, CAPETOWN"	65
„ "LODGE NO. 94 AT THE BEN JONSON'S HEAD".....	72
„ "FRENCH PRISONERS AT LANARK"...	81
„ "FREEMASONRY IN WAR"	105
„ "THE 3.4.5 TRIANGLE IN THE GREAT PYRAMID"	108
„ "THE ROYAL SOMERSET HOUSE AND INVERNESS LODGE".....	166
„ "OPERATIVE FREEMASONRY.....	168
EXHIBITS:—P. 77, 163.	
IN MEMORIAM	172

List of Plates.

PLATE		
I.	AN ANTIQUE APRON.....	Front
II.	CERTIFICATE OF BRITISH LODGE, CAPETOWN.....	Page 66
III.	LANARK PRISONER'S CERTIFICATE ..	82
IV.	THE 3,4,5 TRIANGLE IN THE GREAT PYRAMID ..	108
V.	MARKS OF THE OPERATIVE MASONS	} ,, 116
VI.	" " "	
VII.	" " "	
VIII.	" " "	
IX.	" " "	
X.	" " "	
XI.	" " "	
XII.	PORTRAIT OF WILLIAM PRESTON... ..	142
XIII.	PORTRAIT OF WILLIAM HUTCHINSON ..	154
XIV.	PORTRAIT OF DR. GEORGE OLIVER ..	157
XV.	JEWEL OF "ROYAL SOMERSET HOUSE AND INVERNESS" LODGE	166



Operative and Speculative Masonry, by H. S. Biggs ✓	35	1896-97 ✓
Operative and Speculative Masonry, an attempt to fix the date of the Union of, by H. S. Biggs ✓	86	1900-1 ✓
Operative and Speculative Masonry, The Connection between, by W. H. Wood	33	1936-37 ✓
Operative Freemasonry, by C. E. Stretton	37	1911-12 ✓
Operative Freemasonry (Supplement), by C. E. Stretton	168	1911-12 ✓
Operative Freemasons and Operative Freemasonry, by Dr. T. Carr	111	1911-12 ✓
Operative Lodge of Banff. 1764-1778, by J. T. Thorp	143	1912-13 ✓
Operative Mason and his Mark, An, by A. S. Hall Johnson	26	1960-61 ✓
Operative Mason, up to 1750AD, The, by J. T. Harrison	25	1995 ✓
Operative Masonry and its Relation to Speculative Masonry, by W. H. Riley	81	1928-29 ✓
Operative to Speculative Masonry, Transition from, (Prestonian Lecture), by H. Carr	43	1956-57 ✓

Transects

1896-7	Biggs	
1900-1	Biggs	
1911-12	(3) Stretton / Stretton / Carr	
1912-13	Thorp	
1928-29	Riley	
1936-37	Wood	LLS 8127
1956-57	Carr	1 x 1/2 M
1960-61	Johnson	off cuts 1000 ↓
1995 ✓	Harrison	

PLATE I.



AN ANTIQUE APRON.

Vide p. 29.



CERTIFICATE ISSUED BY THE "BRITISH" LODGE, CAPE TOWN.

PLATE IV.

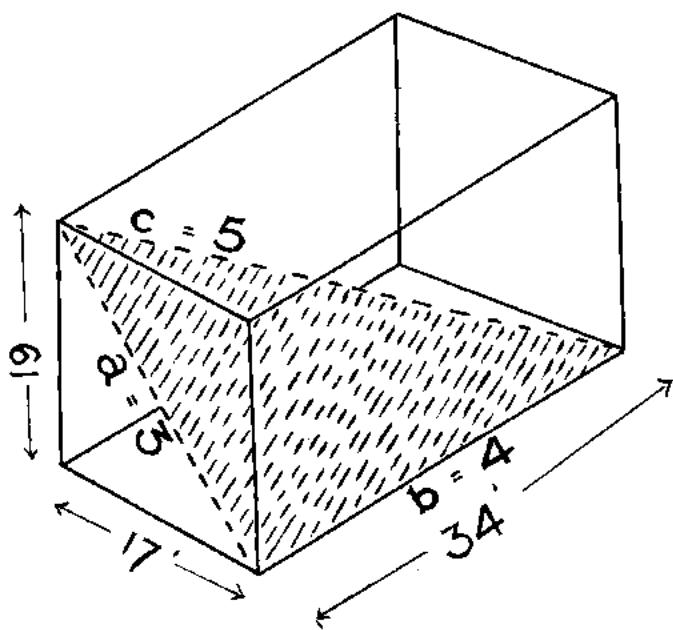

The 3.4.5 Triangle in the King's Chamber of the Great Pyramid.

Vide p. 108.

PLATE VI.

(4). The Blue or Square Talisman.

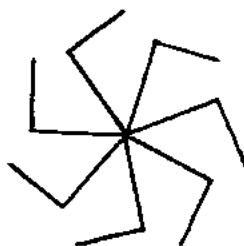
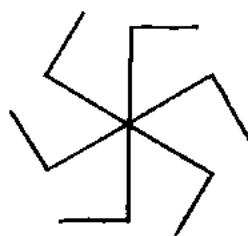
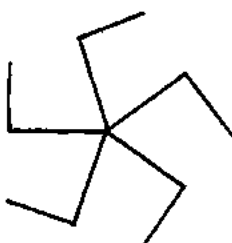
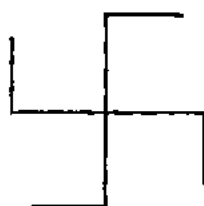
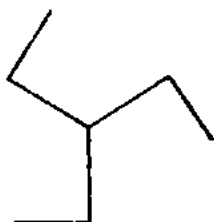
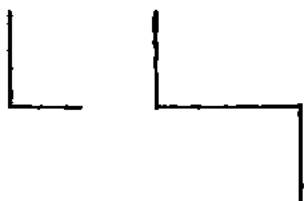

Operative Masons' Marks.

Vide p. 116.

PLATE VII.

(5). The Tau.

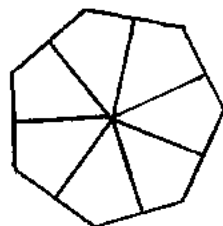
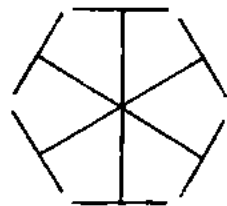
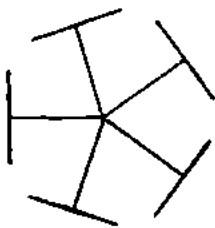
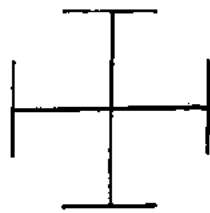
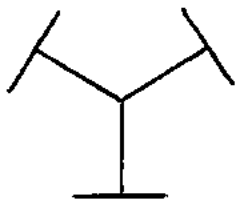
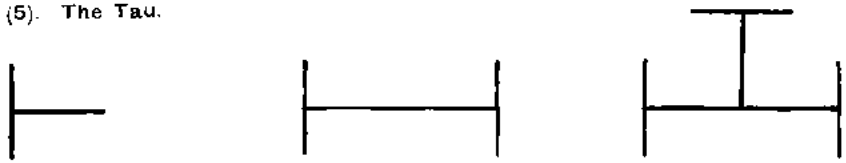

Operative Masons' Marks.

Vide p. 116.

PLATE VIII.

(8). The Double Tau.

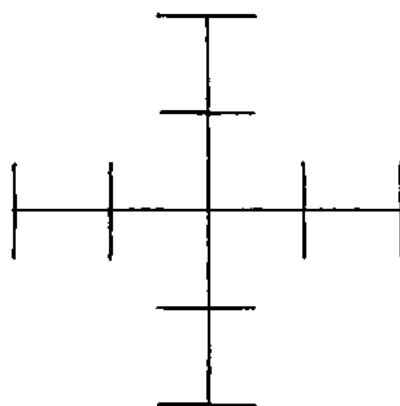
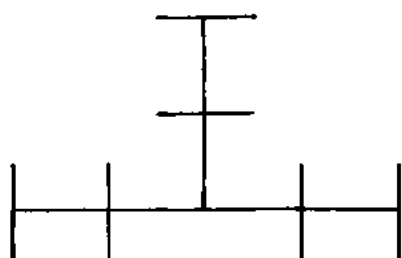
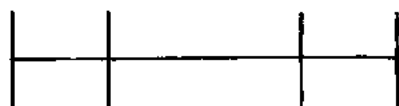
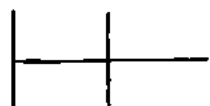

Operative Masons' Marks.

Vide p. 116.

PLATE IX.

(7) The Reversed Tau. (Single and Double.)

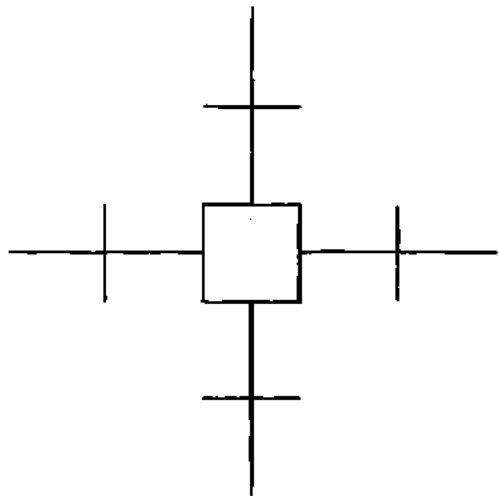
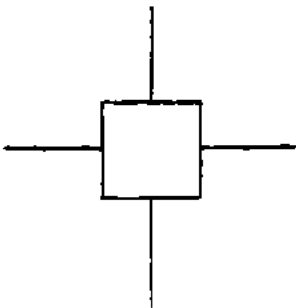
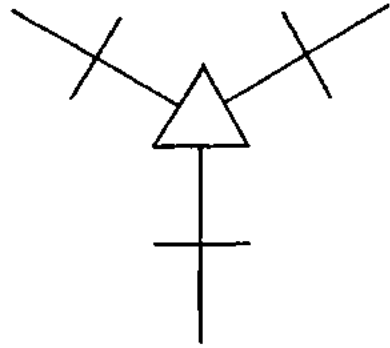
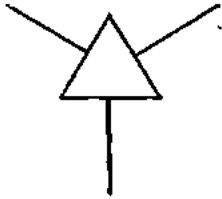

Operative Masons' Marks.

Vide p. 116.

PLATE X.

(8) The Double Square or Octagon.

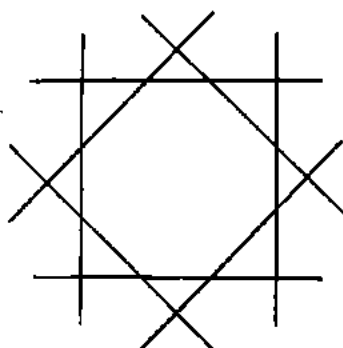

(9) N. or Z. Mark.

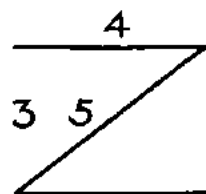
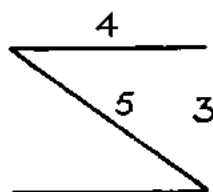
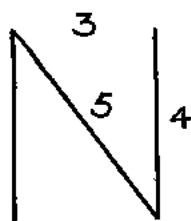

Operative Masons' Marks.

Vide p. 116.

PLATE XI.

(10). Direction Mark

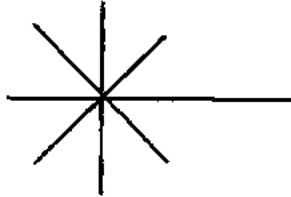

(11) Ground Plan.

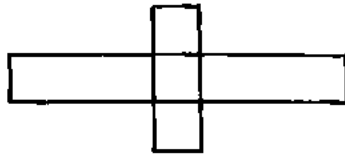

(12). Broad Arrow

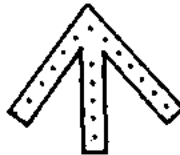

Blacksmith's Mark for Carpenters.

Operative Masons' Marks.

Vide p. 116

PLATE XII.



WILLIAM PRESTON.

1742-1818.

Vide p. 142.

PLATE XIII.



WILLIAM HUTCHINSON.

1732-1814

Vide p. 154.



Dear Sir

Your faithful Broj

Geo Oliver DD

DR. GEORGE OLIVER.

1782-1867.

PLATE XV.



JEWEL OF THE "ROYAL SOMERSET HOUSE AND
INVERNESS LODGE."

vide p. 166.